

**Technical Assistance to Vietnam
on the Establishment
of the Vietnam Securities Depository**

Commissioned by Ministry of Finance Japan

March 2006

Institute for International Monetary Affairs

Forward

This is a report compiled by the Institute for International Monetary Affairs (IIMA) on “The Technical Assistance on the Establishment of the Vietnam Securities Depository” commissioned by the Ministry of Finance Japan for the FY2005 project.

The focus of the research/technical assistance (TA) was on building the infrastructure for a government bond settlement system at the Vietnam Securities Depository (VSD)--- specifically, planning a system framework and forming a legal structure --- which were pointed out as one of the major issues for the future, in the report of “Technical Assistance to Vietnam to Establish the Infrastructure of the Government Bond Market Settlement System,” commissioned by the Ministry of Finance Japan for the FY2004 project.

At the early stage, the scope was only to government bond settlement. However, it was expanded to securities in general which are traded at Securities Trading Center, including stocks because the TA team found that settlement is currently conducted by the same system in Vietnam and the establishment of IT system for settlement does not depend on the distinction of securities for Vietnam.

Various problems were discussed periodically and in a highly concentrated way over a short period of time with the Vietnamese in charge, based on the on-site research and analysis conducted at the State Securities Commission (SSC), Hanoi Securities Trading Center (HASTC), Ho Chi Minh Securities Trading Center (HOSTC) and securities market participants in Vietnam. Then the contents and the fruits of the discussions were fed back to relevant people at the workshop held at the end of each TA topic.

The process began in August 2005 and continued for eight months. From August to November, the research/TA focused on analysis on the current operational flow at the HASTC and the HOSTC. Based on the analysis, the TA team submitted a proposal for the integration of existing systems at the STCs which are going to be used temporarily until 2009 from which purely new IT system is to be introduced at the VSD.

From December to January, the TA focused on recommendation on IT system development plan for the purely new system from 2009. From February to March, TA concentrated heavily on the issue of layered system of securities account. The choice of layered system of securities account is one of the prerequisites for designing and planning of IT system at the VSD. The TA team provided general information of layered system including theoretical pros and cons and made some suggestions to Vietnam in selecting the system. This fiscal year again, the TA team continued to follow-up the draft of Securities Law which is expected to be submitted in May 2006 at National Assembly. This report reflects the whole of this process and all the discussions, which took place in the course of the TA.

The research was conducted by the specialists from IIMA with years of experience in capital

markets and working group members formed by eleven staffs from the SSC, the VSD, the HASTC and the HOSTC with the cooperation of NTT Data, an IT specialist on settlement systems.

The Ministry of Finance Japan who commissioned this research also sent their official to Vietnam to guide the direction of the research.

From November 7 to November 11, nine Government officials from State Treasury, the SSC and the VSD visited Japan to study the Japanese securities markets. The study tour was made possible by generous cooperation of the Ministry of Finance Japan (MOF), the Financial Services Agency (FSA), the Securities and Exchange Surveillance Commission (SESC), Bank of Japan (BOJ), Japan Securities Depository Center (JASDEC), Tokyo Stock Exchange (TSE), Japan Bond Trading Co., Mitsubishi UFJ Securities and Kyoto University. TA had been implemented smoothly due to the close relationship between Japan and Vietnam since that time. The IIMA would like to take this opportunity to express its appreciation to them for their cooperation and warm hospitality.

The research/TA was made possible by the generous cooperation of the Ministry of Finance Japan and the Vietnamese authorities, especially the VMOF, the SSC, the VSD and the STCs. The TA team would like to express its appreciation to them and sincerely hopes that this report will contribute to the development of the government bond market and the capital market in Vietnam. It would be a further pleasure if this report were also to play a part in the development of the settlement system in East Asia and in nurturing the bond market in the region.

The contributing experts to the individual chapters of this report are as follows.

IIMA	Naoyoshi Kinukawa, Director, Economic Research Dept. (Chapter 4)
	Kazuyuki Ichihashi, Visiting Senior Research Fellow (Chapter 1, 2, 3, 4)
	Norihiro Takeda, Economist, Economic Research Dept. (Chapter 1, 2, 3, 4)
NTT Data	Takamitsu Kagyo, Business Development Section Financial business Sector (Chapter 2)

Table of Contents

Abbreviations	1
Chapter 1: Establishment of the Vietnamese Securities Depository	2
1. Results of Last Year’s Technical Assistance.....	2
2. Policies for this Year’s TA	2
3. The Record of Activities from August 2005 and March 2006	5
4. Summary.....	10
Chapter 2: The Operational Flow of the Vietnamese Securities Depository and the Supporting System	12
1. Proposal on the HASTC and the HOSTC Settlement System Integration.....	12
2. Supporting the Designing of the mid to long-term Development Plan of the IT System for VSD.....	22
3. Comprehensive analysis and recommendation on the layered system for VSD	30
Chapter 3: Development of the law on securities settlement	41
1. Outline of this Chapter	41
2. Process for enacting the securities law	41
3. The results of review on 4 th draft of the securities law chapter 5 in last fiscal year	43
4. The results of comparison of 7 th draft of the securities law with 4 th draft in this fiscal year	43
Chapter 4: Conclusion	47
1. Summary of this year’s TA.....	47
2. The importance of making a blueprint	48
3. The requests from Vietnam with regard to future TAs	49
Appendix	51

Abbreviations

BIDV	Bank for Investment and Development of Vietnam
DAF	Development Assistance Fund
HASTC	Hanoi Securities Trading Center
HCMC	Ho Chi Minh City
HOSTC	Ho Chi Minh City Securities Trading Center
IIMA	Institute for International Monetary Affairs
JASDEC	Japan Securities Depository Center
JMOF	Ministry of Finance Japan
SBV	State Bank of Vietnam
SSC	State Securities Commission
STC	Securities Trading Center
TA	Technical Assistance
VMOF	Ministry of Finance Vietnam
VSD	Vietnam Securities Depository
CSD	Central Securities Depository
DVP	Delivery versus Payment
OTC	Over the Counter
PMC	Project Management Committee
RTGS	Real Time Gross Settlement
STP	Straight Through Processing
SWIFT	Society for Worldwide Interbank Financial Telecommunication
WG	Working Group

Chapter 1: Establishment of the Vietnamese Securities Depository

1. Results of Last Year's Technical Assistance

Commissioned by the Japanese Ministry of Finance, “Technical Assistance (TA) to Vietnam to Establish the Infrastructure of the Government Bond Market Settlement System” was provided in FY2004. The TA was based on the TA in FY2003, where the problems related to the Vietnamese primary and secondary government bond markets and the settlement system as well as several possible solutions for those problems were highlighted. For example, with regard to the primary market, the issue that issuances were carried out through various channels according to the various needs of the securities trading center, the central bank and the State Treasury, were pointed out. The related information was not centralized, and issuances and a management were not conducted in an efficient way. With regard to the secondary market, the current Decree on Securities and Securities Market, in effect, prohibits the establishment of an OTC market and the TA team pointed out that prohibition inhibits the stable growth of the secondary market. Regarding the settlement market, the TA team also pointed out that although the current transaction volume was relatively small, there is the possibility of market growth in the future and in view of that prospect, it was necessary to fundamentally review the system and the operational flow. The recommendations to improve the situation were made.

Reflecting the wishes of the Vietnamese government, the Japanese experience to help lay down the legal framework for the Vietnam Securities Depository (VSD) was explained and the draft of the related law was reviewed for the FY2005 TA.

2. Policies for this Year's TA

(1) Issues

The FY2005 TA was planned to focus on the following areas, which were strongly requested by Vietnam in at the end of the FY2004 TA.

A. to carry out a research and to make recommendations on the unresolved issues and problems related to the establishment of an operational flow and the introduction of the system for VSD, which is planned to be launched in 2007¹

B. to follow up the draft of the Securities Law which concerns the VSD

¹ TA team found in this year's TA that the VSD is going to start its operation in May 2006 and become independent in 2009. The organization of VSD has been already established and the staffs have been appointed by the SSC.

The basis of these activities is as follows:

- a. Banking is not the only area of financial infrastructure that is required for economic development. Capital markets are also critical, and needless to say, the bond market is one of the key areas. Developing the bond market also coincides with the ABMI objective of “nurturing highly efficient and liquid bond markets in Asia in order to utilize savings in Asia for investment in Asia”.
- b. The capital markets have yet to be developed. This is, however, an opportune moment in view of future developments to nurture various types of securities and to lay the foundation for a securities settlement system that will comprehensively deal with transaction, matching, clearing and settlement processes.
- c. The Japanese experience in which the integration of multiple settlement organizations operated in parallel occurred, and a huge volume of bond transactions is carried out daily, can be utilized in the development process of the Vietnamese bond markets.
- d. In order for the VSD to be operated efficiently, stably and safely, it has to be operated by the personnel who understand not only the legal aspects of the settlement and operational systems but also the underlying principles and spirit.

(2) The Scope of the Research

Based on the issues above, the TA team planned to conduct the following activities by utilizing the experience of Japan in the development of bond markets.

- A. Last year, the Vietnam Ministry of Finance (VMOF) was the TA team’s counterpart, and the team worked directly with State Securities Commission (SSC) which is under the organization of the VMOF. This year, in order to further ensure that the TA should be more practical, the TA team first considered how to involve the Ministry of Planning and Investment (MPI), which is involved in various policy planning processes. In addition, the TA team planned to create a network of government ministries which play key roles in government policy-making including the MPI, in parallel to the progress of the project.
- B. Last year, the TA team made studies and recommendations on the articles related to the VSD in the draft of the Securities Law. That work will be followed-up in FY 2005 towards the enactment of the proposal. The TA team will monitor whether and how the issues that were pointed out in FY2004 are reflected in the proposal.

- C. There are two possible stages of process in the creation of the operational flow and system for the VSD, which is planned to be established in 2007 and to have comprehensive functions. (a) The first stage is to connect and integrate the IT systems at the Ho Chi Minh City Securities Trading Center (HOSTC) and the Hanoi Securities Trading Center (HASTC) (a preliminary measure). (b) The second stage is to introduce a new IT system based on (a), then to connect it to the head office in Hanoi, the Ho Chi Minh branch and to the back-up system. (to be completed by 2007) The Vietnamese authorities must form a WG to work towards creating a comprehensive IT system that will cover transaction, matching, clearing and settlement, and establishing the series of operational flows. The process of establishing such a system and operational flow should be conducted mainly by the WG, and the TA team will review the problems and make recommendations.
- D. Educational activities, such as seminars held locally, should be conducted to develop the human resources that will support the establishment and the development of the VSD as well as deepening the understanding of market development and organizing among those who will be involved in the policy making processes.
- E. The Vietnamese participants are beginning to have an incentive to write a blueprint for the bond market infrastructure planning. The team will be careful to encourage the move towards self-reliance as part of the TA activities so that the Vietnamese participants may spontaneously write the plans to lay down the overall bond market infrastructure with clear priorities.

(3) The Initial Schedule of the TA activities

The initial schedule the TA team planned is as follows.

July and August

- Establishing a mutual understanding of the activities included in the Scope of Research is necessary for the establishment of the VSD in 2007 and that such activities as described above will be carried out with the Vietnamese participants in the lead with the advice provided by the Japanese side
- Establishing a WG to implement the TA activities
- Making a schedule leading to the adoption of a new system by 2007 specifying the requirements for the IT system to avoid misunderstanding on the initial conditions for creating the system

--Confirming the progress on the work of writing the blueprint for the bond market infrastructure

August to February

- Prioritizing the activities and making concrete schedule
- Adopting a “plan-do-see” review process to ensure that the established schedule will be adjusted flexibly if there are any changes in the circumstances and to meet the objectives in the end.

March

- Holding a seminar to summarize the activities of the TA
- Writing a final TA report

3. The Record of Activities from August 2005 and March 2006

(1) Activities from August to September

With the basic policy as stated above in mind, the TA team informed the SSC of a plan to conduct the FY2005 TA on the following two areas in the beginning of August; a) to design a new system for the bond settlement segment of VSD, and b) to follow-up on the process leading to the finalization of the Securities Law which is likely to be enacted after 2006.

The SSC replied that they would like the TA to be on a) the integration of the settlement systems of the HASTC and the HOSTC before adoption of a new system at the VSD, and b) adoption of a new system for the VSD. They also requested the TA team to include not only bonds settlement but also stock settlement, as well as not to limit to settlements but to include transaction, matching, clearing and registration functions as well.

After visiting the VMOF and the SSC in mid-August with the NTT Data, and after some intensive discussions with the SSC, the TA team and the SSC agreed that this year’s TA will be on a) the integration of the current systems of the HASTC and the HOSTC, and b) comprehensive analysis on the effect of choosing a mono-layered system for the new system at the VSD.

The TA team gained the understanding of the SSC that the TA team will limit its advice to what the objectives of the integration of the two systems should be, based on our observations of their current functions, and the framework under which integration should be directed. The TA team then visited the HASTC and obtained a manual for securities operations from transactions to settlements. The TA team also handed a questionnaire to the SSC so as to clarify the objectives and the policies of system integration.

On the second issue of the effect of choosing a mono-layered system, it was agreed that the TA

team will provide a comprehensive analysis of various layered systems including the possible operational flow when choosing a mono-layered system, and the merits and demerits of a mono-layered system compared to a multi-layered. This approach was chosen since Vietnam seemed to have already decided to adopt a mono-layered system. However, the TA team planned to hold a forum in October for the officials of the VSD and the relevant ministries to discuss whether Vietnam will actually adopt a mono-layered system as planned or maintain a double-layered system, which is the current situation and one type of the multi-layered system. Provided that there is adequate time between this forum and March 2006, which is the end of the TA, the TA team agreed to provide support in planning and designing bond settlement system and support in writing a long-term action plan to design new bond settlement at VSD for further improvement. The TA team began by listing the pros and cons of general layered systems before considering the operational flow under a mono-layered system.

While we were in Vietnam in mid-August, the SSC made a preliminary inquiry about the plans for a nine-people delegation, consisting mainly of the SSC officials, to study the Japanese securities market and whether the IIMA can host the group.

(2) Activities in October

The TA team visited a local consultant in Vietnam in October to explore where Vietnam was going in the choice of layered system. The FY2004 TA revealed that there will be a chapter on the securities settlement system in the new Securities Law and that the layered system will be defined in that chapter. The drafting of the law had not been completed by the time we made the visit and it was still unclear as to which layered system would be chosen.

The following day, the TA team visited the SSC and confirmed that it was still undecided whether a mono or a multi-layered system would be chosen. The SSC then requested the TA team to make a recommendation on the layered system that Vietnam should adopt, as part of the FY2005 TA. After discussions, the TA team and the SSC agreed that the TA team will a) make proposals on the integration of the settlement systems of the HASTC and the HOSTC, b) conduct a study on the layered system that the VSD should adopt, and c) support the VSD to draw the medium to long-term IT development plan at the VSD.

The TA team obtained an operational manual on securities operations from transaction to settlement used in the HOSTC for the analysis on the current system. The team also received the answers to the questionnaire regarding the objectives and policies of the system integration that was handed to SSC in August. As the first step in the TA concerning system integration, the TA team began by creating flow charts based on the operational manuals that were obtained from the two securities trading centers.

At the end of October, the JMOF visited the International Cooperation Department of the VMOF

and emphasized that in order for this TA to be beneficial to Vietnam, it was critical for Vietnam to take initiative in writing the blueprint for bond market development. Then, with the presence of SSC, the TA team explained the content of the TA to the Director of the VMOF.

The next day, the Ta team visited the SSC to further discuss the three areas of TAs which were agreed on during the meeting in the middle of the month. During this visit, both of the SSC and the TA team agreed that the TA on system integration will be conducted between November and the end of December, the TA to support the medium to long-term development plan of the IT system for the VSD will be conducted from mid December, and the TA to study the layered system that should be adopted by VSD will be conducted from January onwards. To hold a workshop after the end of each TA to share the results with the SSC and the VSD staffs from various departments is also agreed.

(3) Activities from November to December

The TA team began to draw a system integration proposal based on the operational manuals which were obtained from the HASTC and the HOSTC, and the flow charts which were drawn up based on those manuals.

The study delegation that the IIMA were consulted about during the visit to Vietnam in August visited Japan at the beginning of November to study the Japanese securities markets. The expenses for that trip to Japan were born by Vietnam side. With the support of the JMOF and accompanied by the IIMA, the delegation visited the JMOF, the Bank of Japan, the Financial Services Agency, the Securities and Exchange Surveillance Commission, Japan Securities Depository Center, Tokyo Stock Exchange and some of the major Japanese financial institutions and received lectures on the Japanese securities market. The IIMA believes that these lectures were invaluable for the members of the mission who will be instructing the Vietnamese securities market. The cooperation extended by the Japanese institutes on this occasion contributed to the smooth execution of the TA activities.

After the visit of the delegation, the TA team visited Hanoi and Ho Chi Minh City between mid November and mid December. First the TA team visited the SSC and was informed that the contents and the schedule of the TA were approved by the SSC chairman. After the approval, the TA team requested the SSC to form a WG with 10 to 15 staffs from various relevant ministries with practical knowledge to implement the three areas of the TAs. The SSC assigned 4 from the VSD, 3 from the SSC, 2 from the HASTC and 2 from the HOSTC, total 11 staffs, as the WG members. Mrs. Phuong Hoang Lan Huong, Deputy director of the VSD, was assigned as the WG leader and Mrs. Nguyen Thi Hoang Lan, Deputy director of the SSC, was assigned as the vice-leader. The other members are from those who are in charge of planning, operation, and IT system for each organization. Mrs. Ha Nguyen Huong, International Cooperation Dept. of the SSC was assigned as the contact person with the TA team.

Then the TA team visited the HASTC and the HOSTC and discussed with the WG whether the current systems and the operational flow of the two securities trading centers matched the TA team's understanding, using the flow charts created from the operational manuals. A system integration proposal was drawn up in parallel with the analysis on the current systems at the two STCs, and a preliminary proposal was presented to the WG at the beginning of December. In the discussion with the WG members and NTT Data, except WG leader, a counter proposal based on Vietnamese ideas was presented to the TA team from the WG. Based on the counter proposal, a revised system integration proposal was written at the WG's operational staff level. The next day, the leader of the WG joined the discussion and clarified that it was preferable to carry out the integration with the current system as much in place as possible, and also preferable to discuss the issues related to the transfer to the new system in the IT development plan TA. More discussions were conducted among the WG members and a final system integration proposal was drawn up. The workshop on system integration was decided to be held in the second week of January.

As regards the TA for the medium to long-term IT development plan for the VSD, the TA team presented a questionnaire as part of its investigation to ascertain the general development plan that was envisaged by the SSC at that point. Along with the questionnaire, the TA team sent a list of issues that Vietnam should take into account as they drew up the IT development plan. The list was made based on the recommendations made by international organizations. The TA team and the WG agreed to start discussions on the IT development plan in January and hold a workshop on the theme in the second week of the month

(4) Activities in January

The TA team again visited the SSC with the NTT Data in the beginning of January and went over the system integration proposal that were agreed at the previous meeting in December, then the TA team and the WG began discussions on the IT development plan. The team received the answers to the questionnaire on the IT development plan that Vietnam was considering, and explained the core ideas on IT development that the Japanese side had. The TA team also informed the WG of the transformation that Japanese securities settlement system has brought about over the years. In order to realize the plans that Vietnam had in mind, the TA team pointed out that it was necessary to establish a project management committee (PMC) by the end of 2006 and to start discussing the important aspects of IT system in detail among those working in the area. Based on the proposal, the TA team discussed the plan with the WG and finalized the proposal for the IT development plan.

The original plan of workshop was to invite about 20 people from the SSC and the VSD, but upon the request of the SSC, the TA team and the WG invited participants from securities companies, banks and IT vendors. This brought the gathering to about 50 people. The workshops on system integration and on the IT development plan were held on January 12 and 13 respectively, and the

results of the TAs were reported at the workshops.

While the TA team were in Hanoi, the SSC requested the TA team to comment on the seventh draft of the Securities Law. The TA team decided to focus on Chapter 5, Securities Registration, Depository, Clearing and Settlement, and began comparing it to the fourth draft which the TA team studied with the Vietnamese WG members in the FY2004 TA.

(5) Activities in February to March

In mid February, the TA team visited Ho Chi Minh City and Hanoi for a week to conduct a market research concerning the layered system. The TA team visited a total of nine financial institutions in both cities including a securities trading center and carried out research on what problems there were in the current system, and which system the market participants wanted to choose, a mono-layered or a multi-layered. After this market research, the TA team reported the results to the WG then held a workshop on March 2 at the SSC with about 30 participants from the SSC and the VSD. The TA team explained the theoretical understanding of the layered systems in general and presented a comprehensive analysis and the results of market research. The WG explained the current double-layered system and introduced the model used by Malaysia which the VSD is researching on as one of the options for selecting a layered system.

The TA team met a staff from Legal Department of the SSC to comment on the seventh draft of the Securities Law and asked for their counter comments. The TA team also received the information on what process there will be before the Securities Law is enacted and the schedule set for that process.

After the workshop on March 2, the TA team met the Vice Chairman of the SSC and reported that the three workshops on the FY2005 TAs, on system integration, the system development plan and layered system had all been carried out.

These are the records of the TA activities from August 2005 to March 2006. Please refer to the appendix 1 for more detail. The schedule of the infrastructure for Vietnam securities market which was envisaged at the end of the TA is shown below as Figure 1.

Figure 1

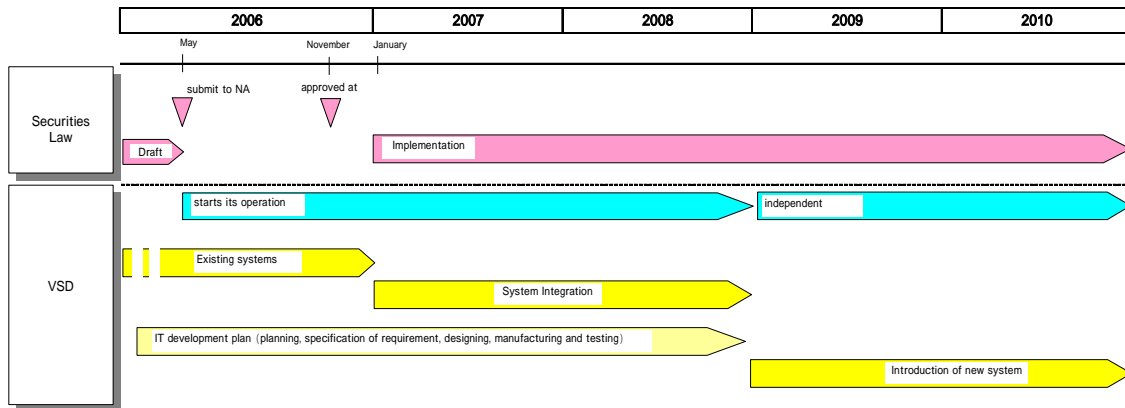

4. Summary

In a normal flow of an IT development plan, there are five stages; planning, specification of requirement, designing, manufacturing and testing. Initially the TA team intended to conduct the FY2005 TA on the planning of bond settlement function of the VSD’s new system, which is planned to be adopted after 2009. However, since it was an urgent issue for Vietnam to create a temporary system for the VSD that would (be planed to) begin in January 2006, by integrating the current systems of the HASTC and the HOST, the TA team decided to include the proposal on system integration as a part of the TAs.

The layered system for settlement is a basic condition that must be decided for planning a new system. It is also an important aspect of the securities settlement that is regulated by the Securities Law. The analysis on layered system and making recommendations on the system that Vietnam should adopt is a part of a follow-up towards the promulgation of the Securities Law. It is in line with our initial policy. For this reason, the TA team decided to include this as a part of the TAs.

The TA team initially agreed to conduct a comprehensive analysis for choosing a mono-layered framework in the new system at the VSD, but the scope of research was extended to comparative analysis of a mono and a multi-layered system and recommendation on the system that Vietnam should adopt. Because of the time and budget restrictions, the TA team did not implement a planning exercise for the bond settlement functions of the new system but in stead, supported in drawing up an IT development plan as something of a roadmap for the whole of the new system.

The TA team believes that it was invaluable to form a WG for the three TAs, and to transfer the know-how while creating a framework whereby the Vietnamese participants took the lead in the project while the TA team answered their questions and gave suggestions. As seen in the use of the

word “cooperation” by the VMOF in the second half of the FY2004 TA, it is necessary for the two sides to work together. It was also the strong wishes of the Vietnamese participants to follow that spirit. By holding a workshop with the Vietnamese participants immediately after the individual TA, the knowledge and experience were not limited to the WG members but helped to educate other relevant people in the field. This method seems to turn out to be very efficient in conducting the TA.

Chapter 2: The Operational Flow of the Vietnamese Securities Depository and the Supporting System

As has been stated in chapter 1, the areas included in this year's TA are the following:

- “Proposal on the HASTC and the HOSTC settlement system integration” (to be used between 2007 and the end of 2008)
- “Supporting the Designing of the mid- and long-term Development Plan of the IT System for VSD” (to be adopted after 2009)
- “Comprehensive analysis and recommendation on the layered system for the VSD” (to be adopted after 2009)

In the current situation in Vietnam, securities transactions from trading to settlement and depository for the listed securities are conducted in both the HASTC and the HOSTC, but independently each other. It was an urgent issue for Vietnam to create a temporary system for the VSD by integrating the current systems of the HASTC and the HOSTC, the TA team decided to include the proposal on system integration as a part of the TAs. The development plan for the completely new system which the VSD is going to adopt from 2009 is also important issue to start discussing as soon as possible. Though the layered system issue which the TA team have discussed in last year's TA, is prerequisite for designing IT system, the TA team found that a selection of layered system which Vietnam going to choose was not yet decided. For that reason, the TA team included the IT development plan for the VSD as well as analysis on the layered systems as parts of the TA. The TA team agreed with the SSC to implement these three TAs with the WG members.

This chapter will explain the concrete discussions and proposals that were made in each of these areas, and the issues to be solved in the future.

1. Proposal on the HASTC and the HOSTC Settlement System Integration

The TA concerning the integration of the settlement system of the two trading centers were limited to advising on the objectives of integrating the current system and in which direction the integration should proceed. This was agreed to by the SSC. The activities in this area were conducted in the following three steps.

First, as a preliminary proposal-(a), we submitted an overall picture of integration. The proposed integrated picture is based on the studies on the relationship between the trading centers and settlement systems in various countries and keeping in mind the possible development of the system after integration (its utilization after the establishment of the VSD). After wide ranging

discussions with the SSC, the TA team came to a preliminary understanding with them that the proposal will be the basis of subsequent work and then began the necessary work for outlining the proposal in detail, such as analysis of the current settlement systems of the two trading centers.

The TA team then submitted the result of the analysis and the idea of integration based on the analysis, as a preliminary proposal for system integration, and obtained some Vietnamese requests-(b). The WG studied the overall picture of integration and came up with a number of requests, and in the end, the TA team submitted the final proposal-(c), reflecting the Vietnamese requests approved by the WG leader.

Although the TA team was limiting this year’s TA to advising on the objectives of the integration of the current systems and the direction in which the integration should proceed, the TA team received strong requests from the Vietnamese side to include an estimation of the network cost. The TA team supplemented the final proposal with a rough calculation of the network cost and presented our final proposal and some points to be considered in the integration process to the SSC and the VSD officials as well as other staffs from relevant financial institutions and IT vendors, at the workshop held in January 12, 2006.

(1) The Preliminary Proposal

The overall picture of the integration that the TA team presented to the SSC in mid August 2005 is shown in Figure 2.

<Figure 2>

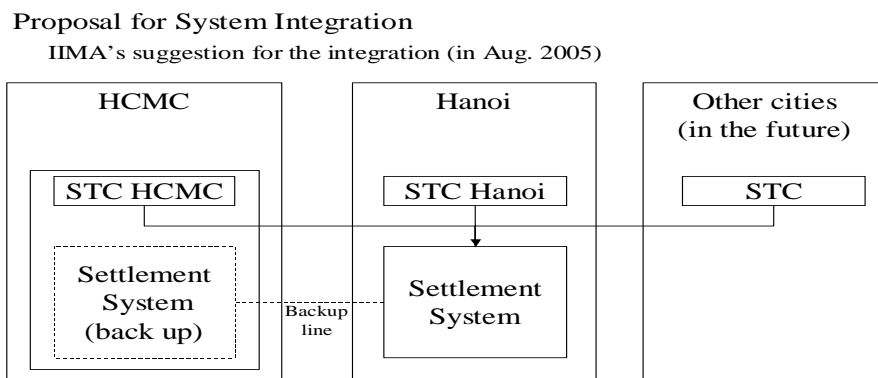

The considerations for this proposal were a) to unify the securities settlement operations, b) to ensure that the integrated system has the possibilities for further development (its possible utilization when the VSD is established) and c) to establish a back-up system.

a) Unifying the securities settlement operations

It is not unthinkable for a separate settlement organization to exist for each kind of securities in a country (for example, the Bank of Japan for government bonds and the Japan Securities Depository Center for others). However, it is unprecedented that there should be multiple settlement organizations for the same kind of securities in a country where a securities settlement system has been properly organized. Currently, settlement of bonds and stocks is conducted at both the HASTC and the HOSTC separately in Vietnam. Although this problem should be solved when the VSD is established, it would help to catch up with the other countries where securities settlement systems are well developed if the HASTC's settlement system were to take over the settlement operation of both trading centers. The head office of the VSD is planned to be set in Hanoi and its branch is in Ho Chi Minh City. For this reason, the TA team suggested to set a settlement system in Hanoi. This method could help to conduct a transfer of settlement function with low cost and efficient way, even if securities trading centers are established in other cities.

b) Ensuring that the integrated system has possibilities for further development (its possible utilization when the VSD is created)

In the proposed integration picture, the HASTC's settlement system will, in effect, take over the settlement operations of the two centers. This means that it is highly possible that this can be utilized as the new integrated system which is planned to be created at the time of the establishment of the VSD. Such an arrangement would not only lower costs but would also mean that operational arrangements would not alter too far, making it less burdensome for the users. The period up to the introduction of new system at the VSD could be utilized for the establishment of operational flow as well as training for the operation officials by unifying the settlement in Hanoi.

c) Establishing a back-up system

The TA team recommended establishing a contingency plan as part of last year's TA. It was made clear through last year's exercise that although there is a back-up machine, it was not possible to switch to it smoothly at a time of emergency. From this experience, the TA team believes that some measure should be taken at the time of integration and suggested that the current HOSTC settlement system be utilized as the back-up system.

The TA team discussed its integration proposal with the SSC and acquired their consent to use it as the basis of subsequent work. The VMOF, which is the supervising ministry of the SSC, also

supported the proposal.

The TA team submitted the SSC a questionnaire to clarify the objectives and policies for the system integration in order to make preliminary proposal.

Question 1

Through the discussions on Aug.9 and 12, the TA team recognizes that there is not any systematic linkage between the HASTC and the HSTC. Is this recognition right?

If the answer is no, please describe the current situation about the link in detail.

Even if the answer is yes, is there any manual process between two exchanges? (For example, sending a document of trade information from the exchange to the other exchange)

Answer;

Yes, it is correct. These two exchanges are independent from each other.

There is no manual process between the two exchanges: no document sending of trade information from one exchange to the other.

Question2

In terms of the current situation as described in the answer for Question 1, what does the SSC recognize as current problems? Please describe them in detail as much as possible.

Answer:

The main problem is finding solutions to links the two systems of the two exchanges. Currently, the two software systems of the two exchanges were designed by the same software company. Therefore, basically the software systems of the HOSTC and the HASTC are similar. However, as the HASTC's system was written latter and taking into account some HASTC's particularities, the HASTC's software is somewhat different from the HOSTC's one. This leads to some differences in procedures and forms of the two exchanges. Technically, we think that we will not be able to run the two software systems simultaneously, so it is likely to choose one from the two. In addition, we must check which part of the chosen system need to be changed or adjusted to fit the VSD's and two exchanges' initial requirements and the requirements of Depository members as well.

Question 3

What is the purpose of the integration of both settlement systems?

What kind of positive effects does the SSC expect from this settlement system integration?

In the future situation with an integrated settlement system, what is expected to be improved on the settlement process by the integration?

What kinds of benefit will be brought to the participants of both exchanges by the improvement?
Please describe them in detail as much as possible.

Answer:

The main purpose is to improve the system efficiency, to unify the registration, depository, clearing and settlement procedures which are initially implemented by the two exchanges, for a single procedure of the VSD. We expect to reduce the volume of required documents in registration, depository and settlement for the market participants by the integration.

Question 4

We recognize that both the SSC and the IIMA team have agreed with the idea as integration which IIMA suggested to the SSC on the last meeting at the second week of August 2005. Thus the IIMA team will work in line with this thinking.

Please make sure that and if you have any comment about that, please tell us in detail.

Answer:

Initially, we have thought about if the settlement of the HOSTC would be used as a back up system. However, this is yet to decide. To be a back up system, it needs to be identical with the operational system. As I have mentioned earlier, it is not easy for HOSTC 's settlement system to become a back up system for HASTC.

The TA team then obtained the manuals for securities operation from transaction through settlement used in the two trading centers as part of sketching the details of the proposal and carried out an analysis of current operations and system.² It was important to understand which parts of the settlement system that are used at the two trading centers could be shared in order to achieve the proposed integration picture. In order to do so, it was necessary to scrutinize not only the application of the system but also the operational procedure. Based on the answers on the questionnaire for the objectives and policies for the integration and analytical works on the operational flow, we presented the system integration proposal (Figure 3) to Vietnam. The key features are as follows.

- Unifying the application of the settlement system and the database
 - (a) Unifying the application of the settlement system

Eliminate the differences in the application of the settlement systems of the HASTC and the HOSTC, which will serve as the back-up system.

² Please Refer to Appendix 2

- In order to make it possible to carry out the settlement of transactions conducted at the HOSTC and the HASTC, the application unique to the HOSTC must be installed into the HASTC settlement system.
- When an emergency occurs at the settlement system of the HASTC, the HOSTC system will be used as the back-up, and the settlement operations that are normally carried out at the HASTC will be carried out at the HOSTC. Consequently, it is necessary to install the application unique to the HASTC into the settlement system of the HOSTC.

(b) Unifying the database

With the integration of this system, the HOSTC's database must be unified into the one at the HASTC.

- Ensuring a DVP settlement

A way to connect the settlement system of the HASTC with the system of the branches of BIDV HCMC, which are the settlement banks, without jeopardizing the simultaneous settlement of securities and funds at the HOSTC, must be considered.

- Back-up through a hot-standby

Since a back-up system hardly exists at the moment, the settlement system of the HOSTC should be held on a hot-standby as a back-up. This will make a quick recovery possible.

<Figure 3>

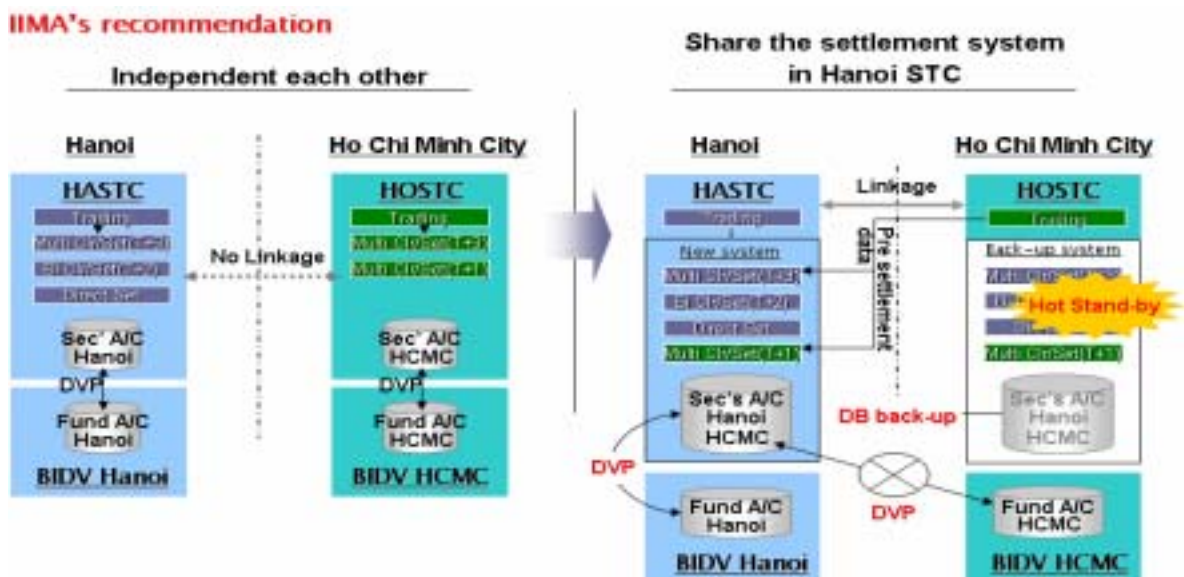

(2) Vietnamese requests

At the beginning of December 2005, the above proposal for system integration was consulted by the WG. The TA team participated in the discussions with the WG and exchanged opinions and answered questions. The requests made from the Vietnamese side in these discussions were as follows.

- (a) The system of each trading center should become a back-up system for the other.
- (b) The systems of the two centers should have the same applications and move in parallel. (This means that settlements would be carried out in both centers as they are at present)
- (c) Settlements should be carried out in both trading centers as currently implemented, but settlement data to be exchanged in real time or every hour in a batch for data consolidation.
- (d) Funds management function of the HOSTC should be transferred to the HASTC to carry out all funds settlement operations of both trading centers in Hanoi.

(3) The final proposal

The TA team pointed out that ensuring that the integrated system has the potential for further development (its possible utilization when the VSD is established) was one of the key aspects of the proposed integration picture. In relation to this establishment, it was important to use the settlement system of the HASTC as the integrated system for the two centers before the adoption of the VSD system for various reasons, including the education of the personnel (to become proficient in dealing with settlement operations gathered from multiple trading centers) who will be necessary when the VSD is established in the future. However, the WG leader opined that the VSD did not want to have an integration that required considerable change in the system, human resources and operational procedures before the VSD was in operation.

The final proposal we presented incorporating (a) to (c) is depicted in Figure 4 and 5.³

³ See Appendix 3 for further details of the procedure.

<Figure 4>

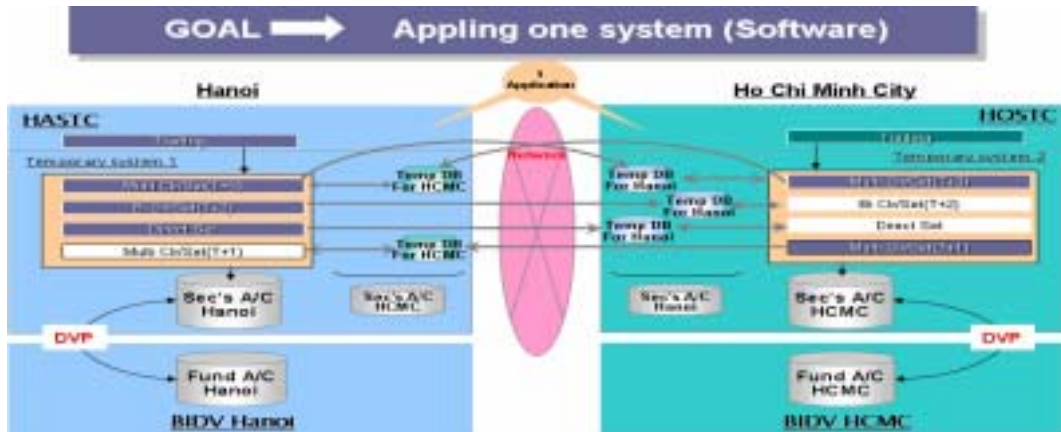

- The HASTC and the HOSTC are to contain the settlement systems which have the same functions.
- The HASTC and the HOSTC are to be linked with network circuit. Settlement information is to be stored at mirroring database⁴.
- Securities and fund settlements are to take place at respective STC and BIDV
- If a failure of securities settlement occurs, the settlement is to be conducted with the settlement information stored at the mirroring database. The fund settlement is to take place at the branch of BIDV at which fund settlement is originally supposed to take place.

<Figure 5>

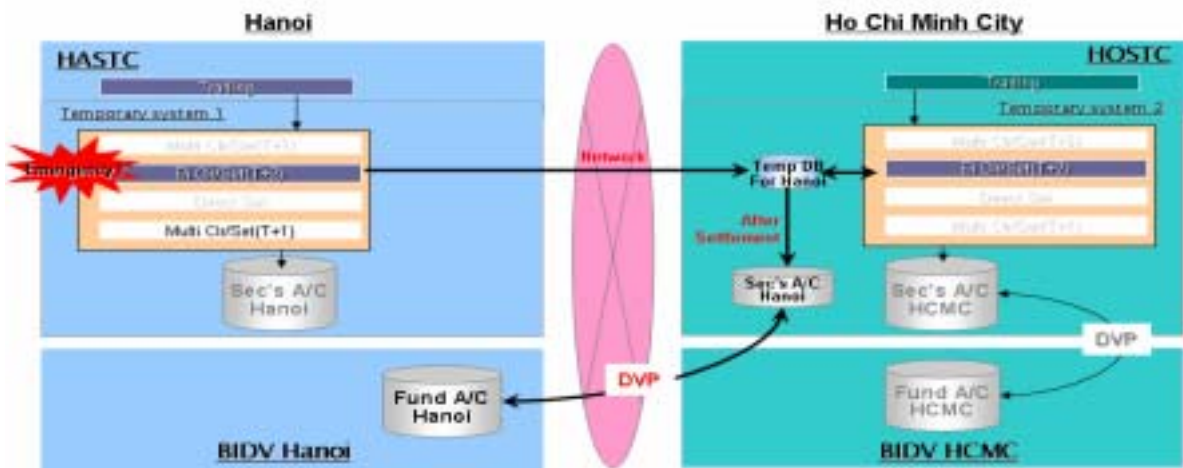

The final proposal was appreciated by the WG leader for “accurately reflecting the Vietnamese requests”. The WG leader further requested specific suggestions on the establishment of a network between the trading centers. Although the TA was originally limited to advising on the objectives

⁴ HASTC/HOSTC contains physically the database which is updated at each HASTC/HOSTC as the same table in their own database.

of system integration and its direction, the TA team calculated the network capacity and types of circuit to connect the two trading centers as well as the cost, and submitted them as a supplement. ⁵ (Chart 1)

- Issues concerning the capacity of the network circuit
 - Frequency with which the settlement system will access the mirroring system: every hour
 - Size of the issued SQL document: 300-500 Kbyte
- Issues concerning network security
 - The current settlement systems are directly connected to the transactions systems (located in the trading centers), but no security measure is being taken since they are located within the trading centers.
 - PIX Firewall (CISCO) is installed in the connections with outside terminals (such as those of institutional investors) and restricts access by illegal parties.
 - Because of these circumstances, it will be necessary to install separate security measures for the network connecting the two trading centers independent of those installed in the in-house network.
- Issues concerning the back-up system of the network
 - There is currently no back-up for the network. There are only back-ups for hardware.
 - Since the objective of integration is to mirror databases, it is necessary to copy the network as well.

Chart 1 show the cost calculated on the basis of the above information, compiled with the help of the Hanoi Office of NTT Communications, which provides network services to corporate customers in Vietnam, and VDC (Vietnam Datacommunication Company).

Chart 1

1. One Time Charges:				
Category	Provided by	Billed by	Charges in VND	Charges in USD
(1) Access Line Installation	Local P&T	VDC	VND 10,000,000	-
(2) FR Application	VDC	VDC	VND 8,000,000	
(3) NTU	NTT Com VN	NTT Com VN	-	USD 4,000.00
(4) Total			VND 18,000,000	USD 4,000.00
* Exchange Rate:			VND 15,919 /USD	[Total in USD:] USD 5,151.00
2. Monthly Charges:				
Category	Provided by	Billed by	Charges in VND	Charges in USD
(1) Access Line	Local P&T	VDC	VND 12,778,000	-
(2) FR Port	VDC	VDC	VND 20,416,000	
(3) FR CIR	VDC	VDC	VND 17,322,000	
(4) Maintenance for NTU [Optional]	NTT Com VN	NTT Com VN	-	USD 200.00
(5) Total			VND 50,516,000	USD 200.00
			[Total in USD:]	USD 3,374.00

(Hanoi Branch) and VDC of Vietnam.

The above is the proposal presented in the TA concerning the integration of the systems of the HASTC and the HOSTC. The study will likely move to detailed analysis of the system in the future, taking into account the actual transaction at peak periods, the contents of the application program and the construction of the hardware, and to the analysis of the administrative management based on the transaction procedure. This will then move onto the more practical aspects of system integration development.

(4) Issues to be dealt with in the future

The following issues are likely to arise in realizing the final integration proposal. Other issues to be solved at more practical level of system integration are listed in Appendix 4. (Charts on attachment 4-1 to 4-5)

<Issues that are likely to arise and suggestions>

-- Comprehensive maintenance and management of the systems in the two trading centers

- Even if the application software of the systems in the two centers becomes identical through the integration process, if the two centers make separate decisions on additional applications or change the operation at the maintenance phase, all the fruits of integration will be lost. It is not an exaggeration to say that the maintenance and management of the software after integration is more important than the integration process itself in making sure that the underlying concept of integration is fully realized. It is necessary to have an arrangement for system maintenance and management that will be applied to the two centers that are geographically apart. Strong leadership and strict management are necessary.

-- Establishment of a back-up system that takes the creation of Business Continuity Plan (BCP) into account

- It is necessary to test whether it will be possible to switch smoothly to the system of the second trading center if an emergency occurs in the first. This test should be conducted at the market-wide level with securities companies and other users taking part. It is not enough to have the back-up system as hardware. Integration must be carried out so that operation will continue smoothly even when there is an emergency.
- As a contingency measure, it is necessary to double the circuit that connects the HASTC and the HOSTC. Separate carriers should be used for the circuits.

--Clarifying the current settlement procedures in view of the future VSD establishment

- According to the WG leader, a completely new system from the current one is planned to be installed at the time of VSD establishment. If a completely new system is adopted, there is a risk that settlement procedure will change extensively and create significant confusion among the users of the system. (users within the VSD, securities companies, etc) It will become necessary to clearly show which application in the new system of the VSD will take over what part of the current procedure, i.e. to provide a comparison of the applications of the current and the new system. Clarifying the current settlement procedure is a prerequisite for this comparison. The TA team used the operational manual from the two trading centers to analyze the current procedures, and hope that the result of that analysis will be used effectively when the new system is installed.

2. Supporting the Designing of the mid to long-term Development Plan of the IT System for VSD

As regards the establishment of the VSD, the discussions at the initial stage of the TA were on an integrated government bond settlement system. However, during the dialogue based on the answers to the questionnaire presented to the SSC by the IIMA, the SSC made it clear that it envisaged the VSD as a unified depository that could conduct settlement of all securities. The SSC also requested a completely new system for the VSD, and not an extension of the HASTC and the HOSTC system integration as suggested in Chapter 2 -1.

The VSD will have a similar function to that of the Japan Securities Depository Center (JASDEC), which began its operation in October 1991, even though the VSD, as a unified depository, will deal not just with government bonds but all securities. The Japanese experience in reforming the securities settlement system can be fully exploited since Vietnam will create the VSD, which will be the Vietnamese version of the JASDEC.

In this chapter, the basic problems concerning a unified depository that was pointed out in the 2004 report⁶ will be reviewed and then the ways to overcome those problems as a means to deal with issues related to the establishment of the VSD will be examined. We will then study the principles that should be applied in order to deal with the VSD establishment planned for 2009 in a concrete and efficient way.

(1) From the 2004 Report

Chapter 2 of the FY2004 TA report, “The current situation of the government bond settlement

⁶ Research commissioned by the JMOF in 2004, titled “Technical assistance project to organize the market infrastructure for the settlement of government bonds in Vietnam.” (IIMA)

system in Vietnam and the establishment of an independent depository in the future,” deals with the current situation of the Vietnamese securities settlement system and the issues for the future.

Three major problems to be solved were pointed out.

<Issues>

(a) There are too many routes for issuance and distribution of government bonds, and the settlement system is not fulfilling its function.

(b) The system to cope simultaneously with securities transfer and fund settlement is not operating adequately (Strictly speaking, DVP settlement is not conducted)

(c) There are no provisions (such as RTGS, STP) to deal with the increase in settlement risk which will occur with the increase in transaction volume due to liberalization of OTC and repo market creation.

A) Issues concerning (a)

The fact that there are many routes for issuance and distribution of government bonds makes it extremely difficult for the State Treasury to manage their issuance and balance in a unified way as part of the national treasury. State Treasury within the VMOF is in charge of handling the overall issuance balance and rights associated with government bonds. However, information concerning the balance and rights of government bonds issued by non-VMOF entities, such as the SBV or the DAF, are exchanged by fax or e-mail, making the operation more risky. The number of transactions within the trading centers are said to be still few⁷ and most transactions are concluded outside the trading centers. This seems that there is still room for improvement for both the management of government’s debt balance (how much the government owes) and the relationship of rights (from who the government is borrowing) and IT system to support those.

B) Issues concerning (b)

Fund settlement notification is e-mailed to BIDV, which is the designated bank for fund settlement, then a BIDV staffs confirm the content of the e-mail manually and begin to carry out the necessary settlement operation, again manually. This means that there is an interruption in straight-through-processing (STP). This process shows that the transfer of securities and fund settlement are carried out manually at about the same time. (This information is based on the interviews conducted during a visit to Vietnam in September 2004) It is necessary to have a true DVP settlement framework where the system is collateralized instead of the current arrangement, which is a DVP arrangement only in name.

⁷ 93% of the transactions at the HOSTC are stock transaction (source: paper titled “Securities Markets in Vietnam and their system” by Kawazu, Shinsuke, specialist sent from JICA (April 19, 2002)

C) Issues concerning (c)

As evidenced by the over-heated atmosphere of the trading centers, the volume of the settlement transactions that are dealt with in the trading centers is increasing rapidly.⁸ With the increase in the transaction volume, the settlement risk is becoming all the more serious since there is still a considerable amount of manual work, as well as the use of signatures on various transaction reports, the use of fax, and because the applied settlement system is designated-time net settlement (DTNS), which is not DVP settlement in a strict sense. In order to solve these problems, it is vital to adopt RTGS and STP in order to achieve DVP settlement as mentioned in B) as well as to fully develop the system.

These are the issues and problems that were pointed out in last year's report. The planning philosophy behind solving these problems is extremely important when developing the VSD system. (not only the IT system but also system planning and legal arrangements) Next, we would like to explain the reforms of the securities settlement system that took place in Japan, and the lessons from that experience that may benefit the planning for the creation of the VSD.

(2) Securities Settlement System Reform in Japan

The way in which the Japanese securities settlement system developed and the spirit of the Securities Depository Law are lessons that can be applied to the establishment of the VSD.

The history of securities settlement in Japan began with "the era of delivery (1948-1981)". The second stage was "the beginning of depositories with the Bank of Japan-Net, BOJ-NET (for government bonds) and Securities Depository Center (1981-2002)". Now we are at "the beginning of the paperless securities era (after 2002)". During these years, progress was made in the securities community, by studying the direction in which securities settlement system reform should go, discussing the division of labor between the private and the public sectors and applying the agreed results thoroughly.

A notable development in those years that spearheaded the reform is the creation of the Japan Securities Depository Center (JASDEC)⁹ and the operation of its system. The "Law concerning Depository and Book-Entry Transfer" was enacted in May 1984, and under this law the center was created as a foundation in December 1984 to play the central role in the new system. JASDEC

⁸ The closing price of the VN Index at the HOSTC on February 22, 2006 was 364.44, a historic high. It was a rise of 39.98 points (12.3%) compared to 324.46 of February 13, 2006.

⁹ JASDEC was appointed the depository and book-entry organization by the Minister of Law and Minister of Finance in May 1985, and is a CSD which conducts securities settlement through account transfers for stocks, etc. It was approved as an authorized foreign securities depository by the American Securities and Exchange Commission and by the British SFA in 1993, and by the German Banking Federation in 1997.

began its operation in October 1991 and is the only one of its kind in Japan. The method used here is to replace the traditional physical exchange of securities and money with a system of concentrating all securities that are settled at a depository organization. This will avoid the physical transfer of securities¹⁰ by using the securities accounts at the depository and nominally concluding the settlement by moving the securities from the account of the seller to the buyer. The participants of the JASDEC currently number over 250. They are securities companies, banks, trust banks, insurance companies (life and non-life insurance), securities financial companies, securities exchanges, Japan Securities Dealers Association, etc.

The Japanese settlement system has continued to consider further reform. Remaining problems with the domestic settlement system have been contrasted with foreign systems. Then a future vision for the domestic settlement system for various products (stocks, government bonds, general bonds, short-term corporate bonds, investment trusts, etc) was written, problems to be solved to achieve that vision were illuminated, and a master schedule to deal with those problems for the securities community as a whole was drafted.

It is reported¹¹ that it will be necessary for the master schedule to continue to be updated and detailed as necessary under PMC for reform promotion, a public-private sector joint endeavour. Since the work of the different sections of the committee is closely associated, close coordination among those sections will be necessary to change or adjust the schedule. Establishment of the PMC has been the key to smooth cooperation. It was critical that a consensus for the reform program was established among the market participants and a wide range of those who are involved in the reform, and a public-private joint structure was created to carry out surely the large-scale reform program by setting up the PMC.

(3) Proposals towards the Establishment of the VSD

So far, we have gone over the reform that was carried out in Japan on its securities settlement system. Looking at the problems that Vietnam faces regarding the securities settlement system and studying the aspects that need to be considered for the establishment of the VSD, the critical issue is to secure a consensus on the domestic securities settlement system, and to assure unification of applications (securities registration, transfer, depository etc.) and DVP.

Going over the issues (a) to (c), (a) should be solved by unifying the settlement system, and we

¹⁰ This is called the immobilization of securities. Securities are regarded as physical paper and are deposited together at securities settlement organizations. Although a physical evidence of securities does exist, they do not circulate in the markets.

¹¹ “Towards Japan Securities Settlement Systems and Infrastructure Reform”, November 2002, by The Committee for Reform of Securities Clearing and Settlement System and The Securities Settlement System Reform Promotion Working Group

understand that VSD, as a Vietnamese version of the JASDEC, will be established for that purpose. The securities depository and custody bureaus that exist in both trading centers should be unified as the VSD. The OTC trading that has started from mid 2005 at the HASTC should be included in the VSD. All securities settlements conducted in Vietnam should be carried out at this new organization.¹² This will meet the written objective of the VSD, which is that it should “promote a securities market that is well-organized, secure, highly transparent, fair and efficient, and should protect the legitimate interests and rights of investors”.

Concerning (b) and (c), it is necessary to establish the VSD where securities settlements are all concentrated as mentioned in (a), and a framework where there can be a systemized DVP settlement between the fund settlement banks (Hanoi head office of BIDV and HCMC offices). It is most important for Vietnam, that is just beginning its growth period, that securities and fund settlements can be conducted in real time and simultaneously, especially when the number of market participants and the securities issuing entities are likely to be increasing rapidly as can be predicted from the increase in the volume of transactions. As is mentioned in the FY2004 TA report, international recommendation concerning securities settlement¹³ of CPSS/ISOCO have advised about RTGS and DVP, and this advice should be compared from the start with the potential VSD framework.

The important aspect of this extensive work is to share the guiding philosophy for approaching this issue among the public and private sectors. Creating a master plan and carrying it out is the way to realize that philosophy. As a concrete measure, a Vietnamese version of PMC should be established, a clear understanding of the current organizational, legal and IT system aspects of the Vietnamese securities settlement system should be acquired, and then the ideal securities settlement system should be mapped out on a realistic road map.

The TA team conducted a simple survey with the SSC before making the proposal concerning the establishment of the VSD as part of the TA activity. Questions concerned “the system application that should be realized with the VSD” and “the priorities among the applications that should be realized and the time table”.

Q1. What are the system applications that should be introduced at the VSD?

A. A full-line of system application (matching, clearing, settlement reporting, etc) is necessary.

Q2. What are the priorities among the application that should be introduced and their time table?

¹² Refer to Chapter 2-3 “the Layered System that the VSD should Adopt” concerning the debate on the mono and multi-layered systems.

¹³ “Recommendations for Securities Settlement Systems” published by the Committee on Payment and Settlement Systems (CPSS) and the International Organization of Securities Commissions (IOSCO)

A. To start the full-line operation of system application at the beginning of 2009.

The comments and requests from the Vietnamese were based on government decisions, a policy that had to be followed, but debate on “why something had to be so” or “how they can be realized” had only started. Making a concrete image of what the system application should be based on, the current situation of the Vietnamese securities community or the economic situation and making a blueprint of the system applications formed on the basis of realizing the proposed system are one of the issues to be considered in the future.

The TA team and WG hold a workshop on January 13, 2006, with participants from not only the SSC but also relevant ministries, financial institutions, IT vendors and so on. The TA team made presentation on PMC structure in Japan (Figure 6), the role and activities of PMC (Figure 7), the needs of PMC in Vietnam (Figure 8) and IT system development plan for the VSD (Figure 9). The TA team emphasized that establishment of PMC which is formed with the SSC, relevant ministries, securities market participants and IT vendors is required at first to start concrete discussion to achieve full-line operation at the beginning of 2009 as Vietnam strongly requests. Such activities will undoubtedly help make the introduction of new systems at VSD more efficient and effective.

Figure 6¹⁴

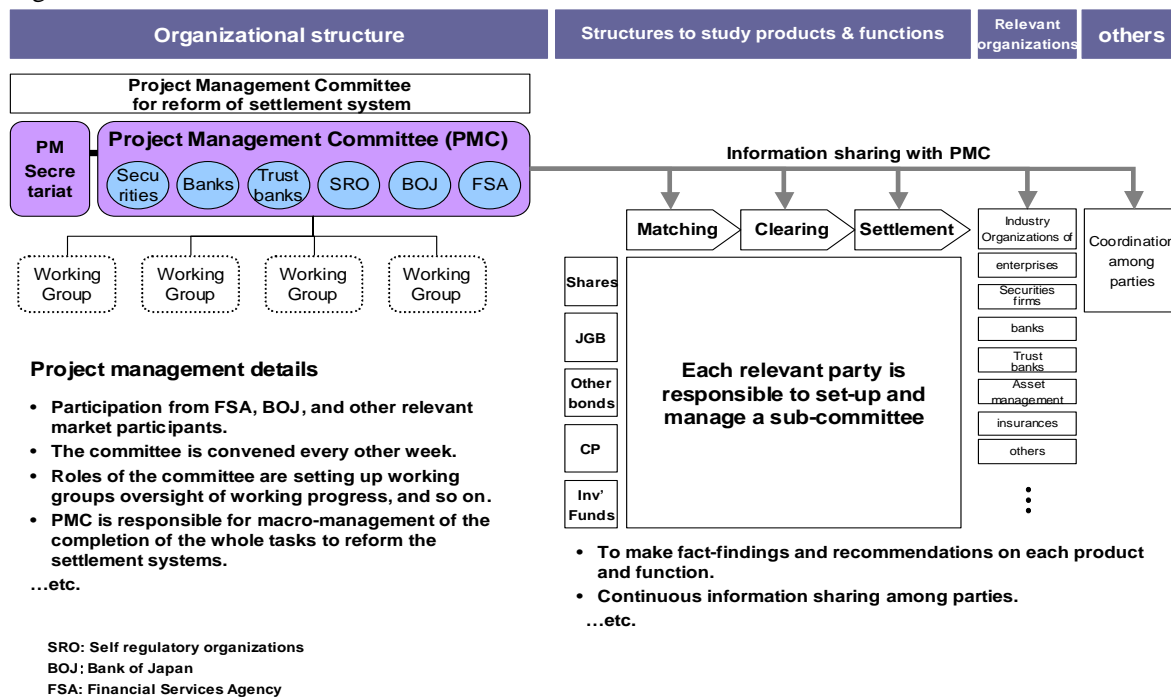

¹⁴ “Towards Japan Securities Settlement Systems and Infrastructure Reform”, November 2002, by The Committee for Reform of Securities Clearing and Settlement System and The Securities Settlement System Reform Promotion Working Group

Figure 7

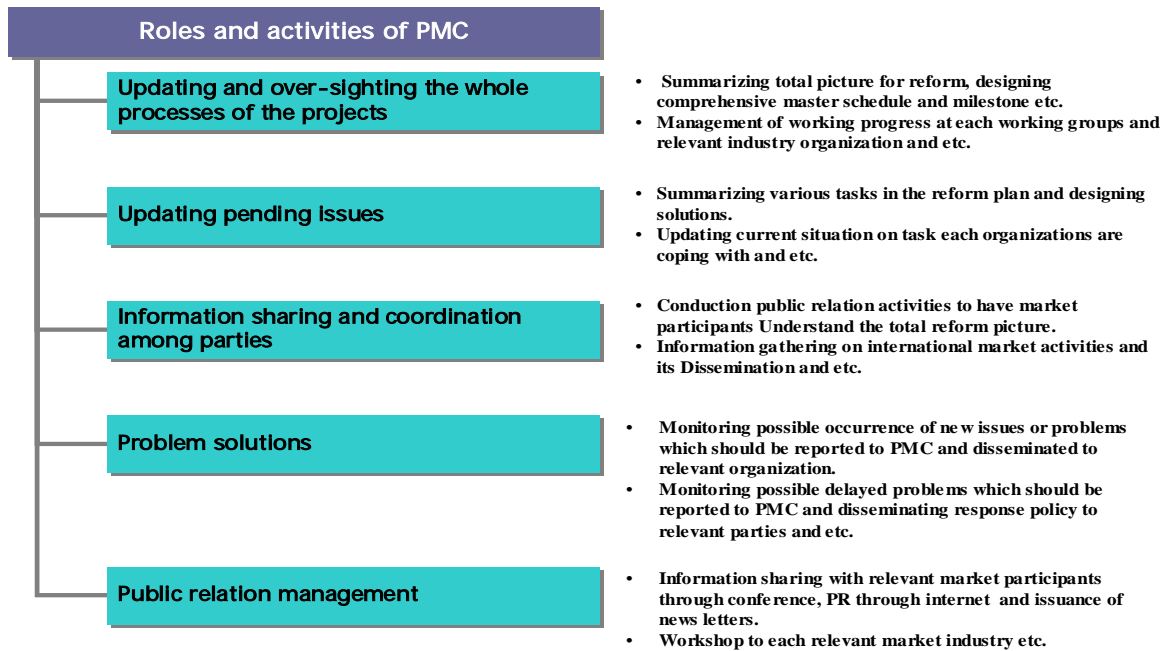
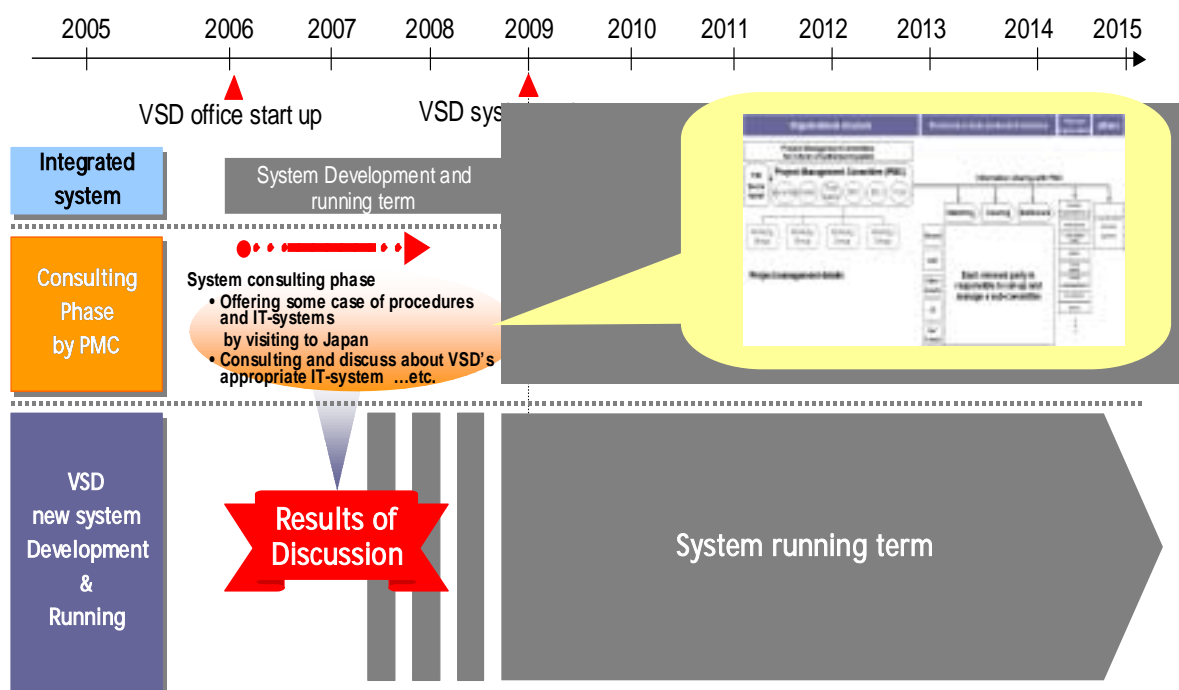

Figure 8



The system integration which is described in this chapter is planned to implement after the VSD starts its operation in 2006. The TA team suggested Vietnam to establish a PMC as soon as possible and start concrete discussion with public and private sectors to specify the requirement of

IT system, to start programming and testing sequentially in parallel with actual operation. The TA team also suggested Vietnam to prioritize the functions which the VSD should accommodate to discuss the strategy efficiently. The prioritization could be dividing the development phases into three as the first one is for settlement function including registration and depository, the second one is for matching and the third one is clearing. The Figure 8 is an example of the TA team's idea to meet the requirement of Vietnam that VSD is to accommodate full-line operation of system. The schedule introduced here is not easy to achieve comparing with a general IT development plan. In order to achieve the goal, Vietnam is required to ensure the funds for the development and human resources and to implement the plan under the credible management system. The TA team also mentioned in the workshop that the development period depends on the requirement of the functions, human resources and costs, and that there is a limitation of shortening the period and the increase of the human resource which the VSD can introduce in the project.

Figure 9

Our suggestion with regard to scheduling of IT-development is to divide various phases of the development terms (project terms) over reasonable time frame.

1. **At first phase is to develop the settlement function (include registration and depository) of VSD.**
2. **Second phase is to develop the matching function.**
3. **The last phase is to develop the clearing function.**

<<example>>

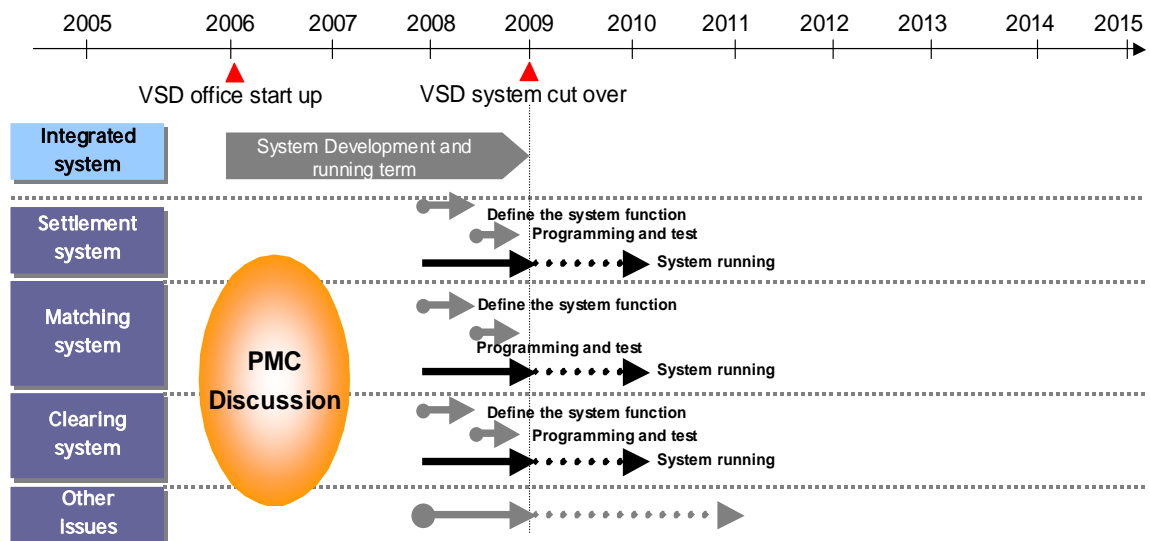

(4) Summary

Much progress has been made in the securities businesses in 2005 due to the efforts made by the

Vietnamese government and the SSC. As for the HOSTC, VINAMILK¹⁵ which is one of the largest companies in Vietnam was listed in January 2006 and a Taiwanese cable manufacturing company was listed for the first time as a foreign company. As for Hanoi, the HASTC was established in March 2005, and it is reported the historic high in transaction amount on February 27, 2006¹⁶. The upper limit to the ratio of stocks that can be owned by foreigners rose from 30% to 49%¹⁷, and foreign institutional investors are likely to increase their holdings of listed stocks. Repo transaction of stocks was deregulated. As for bond market, the VMOF named the Standard Chartered Bank (Hanoi Branch) as the underwriter for government bonds. The year was full of securities related news.

These developments suggest that the rapid and huge increase in settlement volume because of the rapid growth in the activities of the securities market could happen in the “near future”. It is necessary to prepare for the increase in the number of settlements that will occur from the increase in the number of listed stocks. On February 20, 2006, the VMOF announced a five year plan to develop the securities market and a target was set to increase the current value of the domestic stock market to 10%-15% of GDP by 2010. The plan aims to enlarge the securities market through restructuring exchange centers, pumping more goods into the market, and encouraging securities services. All this indicates that with the expansion of the market, the governance issue will arise. Then, following the flow of the times, paperless securities will become an issue to be considered. Since Japan is already studying the arrangements and system associated with paperless securities, she will be able to contribute to the Vietnamese discussion in the future. All this will effect not only how to maintain the credibility of the HASTC and the HOSTC but also confidence in the investment environment of Vietnam. As mentioned above, it is all the more important for both the public and the private sectors to join hands to examine the kind of structure that is needed in the future as well as its most efficient application. This means that the PMC would make even a greater contribution if it examines not only the issues concerning the establishment of the VSD but takes a more comprehensive look at the overall reform of the Vietnamese securities market.

3. Comprehensive analysis and recommendation on the layered system for VSD

In the course of creating a new system for the VSD that is planned for 2009, the choice of a securities account layered structure is an important prerequisite that will greatly affect the conditions

¹⁵ 109,350 stocks (face value 10,000 VND) were traded on the day the company was listed. The closing price was 53,000 VND. The number of listed shares was 150 million, valued at 531 million USD.

¹⁶ The historic high of about 66 billion VND (about 490 million JPY) was recorded as the transaction amount on 2/26/2006 at HASTC (OTC market). The HASTC Index rose by 4.41 points to 98.84. Trading volume was 5,062,950.

¹⁷ Prime Minister Pham Van Khai eased the limitation on the ration of stock holdings by foreigners in the stock market from 30% to 49% on September 29, 2005.

of IT system development. Currently Vietnam adopts a double-layered system which is a kind of multi-layered system. Under the double-layered system, the book-entry system is applied and the securities listed on the securities trading centers and owned by investors are all held as commingle base in the customers' account at securities companies. This is that the government, which is the regulatory authority, can not directly supervise the transactions and the balance of each market participant. This seems to be the reason why Vietnam is considering a different system from the current double-layered system for the new IT system to be adopted at the VSD. They are studying and collecting information on the various models used in different countries.

In this circumstance, the TA team conducted a comprehensive analysis of general types of layered systems at the request of the Vietnamese authorities as part of this year's TAs. In addition to a theoretical analysis, we also conducted a survey on the securities account layered system among the participants in the Vietnamese securities markets. We reported the results of both the survey, as the voice of the market, and results of the analysis at the workshop on March 2.

(1) General concept of Securities Account Layered Systems (mono and multi-layer structures)

Securities account layered systems can be roughly grouped into two types as a mono and a multi-layered structure. According to the Reform Promotion Center for Securities Clearing and Settlement System of Japan, a mono-layered structure is "the method of account management that was specified by the Law Concerning Book-Entry Transfer of Short-Term Corporate Bonds of Japan. It was changed to a multi-layered system by the new Law Concerning Book-Entry Transfer of Corporate Bonds, Etc. This is the system where transfer settlement agents directly manage the account books of all final investors. If transfer between accounts should occur at transfer settlement agents for all transactions, then the administrative burden on the agents may increase." The Figure 10 below illustrates this system. The characteristics of a mono-layered system are 1) the investors have the ownership rights of the securities held in the accounts of the securities depository, 2) all investors must open an account at the securities depository, and 3) participants in this system are the securities depository (Central Securities Depository) and investors.

In a mono-layered system, if investor A buys securities from investor B, transfer of securities will occur directly between the accounts of the two investors held at securities depository.

Figure 10

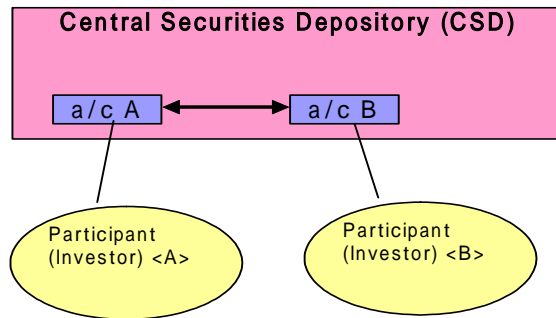

A multi-layered system is explained as follows: “This is a system under which the account books of the final investors are managed at an account management institution, and the account books of the account management institution will be managed by the depository. The depository will manage only the account balances of the account management institutions, which are the direct participants in the depository. The account management institutions manage the account balance of each final investor.” The Figure 11 illustrates a multi-layered system. The characteristics of a multi-layered system are 1) the investors have the ownership rights of the securities held in the accounts which are opened directly at account management institutions, 2) individual investors can choose the organization with which they open an account, 3) the participants in the system are the securities depository, direct and indirect account management institutions, and investors, and 4) investors’ securities are deposited together into the customers’ accounts which are opened with the account management institutions.

Under a multi-layered system, when investor X buys securities from investor D, the transfer of securities occurs between the accounts of C and D both held at direct account management institution B. No changes occur in balance at the B customer’s account which is held at the securities depository, and so there will be no transfer with this account.

There could be some reasons why investor X may have an account with indirect account management institution C instead of direct account management institutions B. One of the reasons could be counterparty risk. Through this arrangement investor X basically acquires credit only from indirect account management institution C and not from direct account management institution B. There could also be a communication issue. For example, if investor X is a foreign investor and if the direct account management institution C is a global custodian from the same country and the direct account management institution B is a local sub-custodian, then, investor X could easily choose C as its custodian because it is easier to communicate with C. As seen in this example, investors have a choice of where to open an account under a multi-layered system.

Figure 11

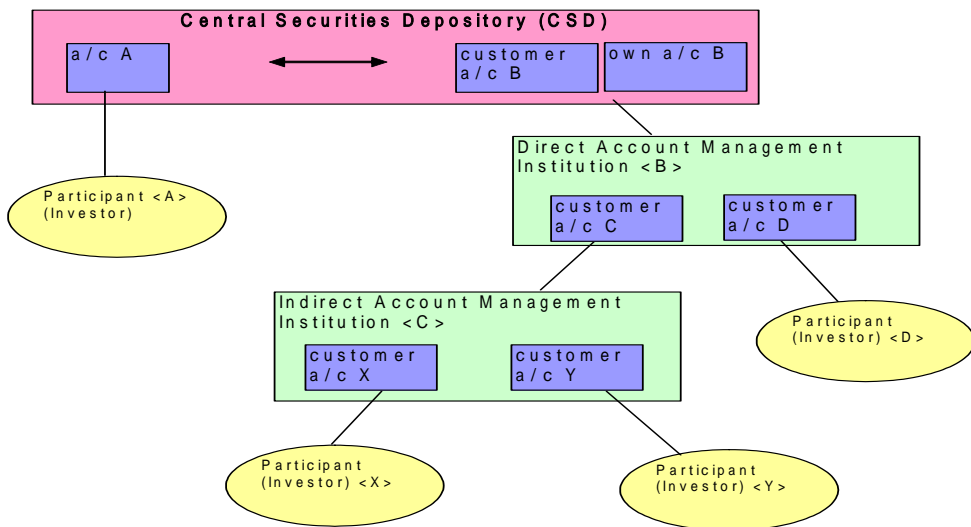

(2) The Double-layered System currently adopted in Vietnam

Currently Vietnam is applying a double-layered system, which is a kind of multi-layered system. Depository members, such as securities companies and banks can open their own account and customers' accounts at the trading centers. Investors open their account as a customers' account at a depository member institution. The securities in customer accounts are commingled. As the exception, the Decree 144, article 40 states that in some special cases, the state bank of Vietnam, credit institutions and others that are allowed to participate in bidding, issuing agents or underwriters of Government bonds can open the depository accounts for Government bonds at the Securities Trading Center. The following Figure 12 illustrates the Vietnamese system. The special case stated above is shown as the exceptional Depository members in Figure 12.

Figure 12

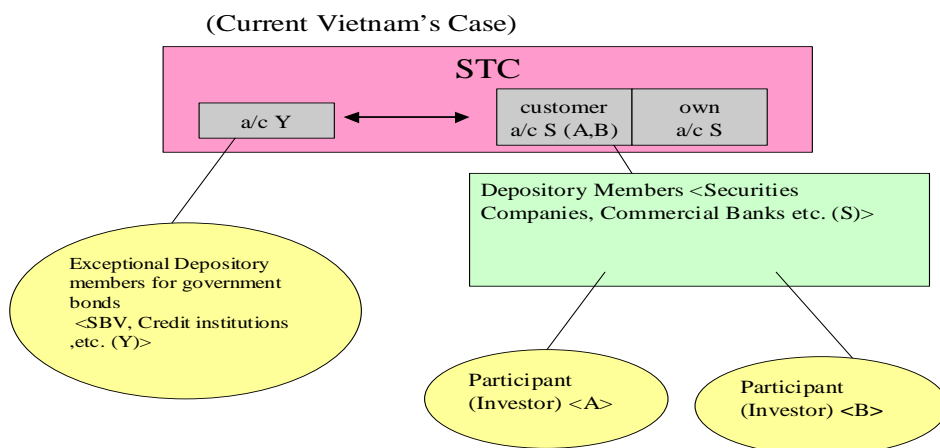

(3) Theoretical pros and cons of Securities Account Layer System

We conducted a theoretical analysis of pros and cons of a mono and multi-layered system for market participants. The results could differ according to the development stage of a securities market, and customs and regulations in individual markets. However, it is still valuable for Vietnam to understand the theoretical pros and cons for considering the layered system on their own.

Chart 2

Type		VSD	Securities company	Investor	Regulator
Mono-layered system	Pros	<ul style="list-style-type: none"> more revenue in terms of safekeeping fee is expected in comparison with multi-layered system 	<ul style="list-style-type: none"> safekeeping cost by securities company is limited to what is arisen from own securities account. 	<ul style="list-style-type: none"> not especially 	<ul style="list-style-type: none"> monitoring all the transactions and the balance for every single participant on real time basis is possible easier for tax collection
	Cons	<ul style="list-style-type: none"> more operational risks for safekeeping due to the number of securities accounts corresponding large volume of transactions custodians are excluded 	<ul style="list-style-type: none"> opportunity for earning safekeeping fee as a custodian is lost 	<ul style="list-style-type: none"> additional cost for maintaining securities account and system maintenance in CSD lost of options where to open its account 	<ul style="list-style-type: none"> as the number of securities accounts opened in CSD increases, additional costs for monitoring are expected
Multi-layered system	Pros	<ul style="list-style-type: none"> lower operational risks with less number of accounts and transactions custodians are qualified to participate 	<ul style="list-style-type: none"> opportunity for earning safekeeping fee as a custodian is expected 	<ul style="list-style-type: none"> efficiency of operation and reduction of operational risks and safekeeping costs are expected by using credible custodians. 	<ul style="list-style-type: none"> monitoring costs are stable because of the increase of the number of accounts opened directly in CSD is limited (instead, reporting obligation is required for every indirect participant)
	Cons	<ul style="list-style-type: none"> less revenue in terms of safekeeping fee is expected in comparison with mono-layered system 	<ul style="list-style-type: none"> safekeeping costs for customer accounts are expected but those are usually to be charged as custodian fee on customers 	<ul style="list-style-type: none"> not especially 	<ul style="list-style-type: none"> not especially

VSD as a depository can expect more account management fees under a mono-layered system because all participants are to directly open their accounts with VSD. On the other hand, because there would be more accounts and transactions to manage under the mono-layered system, operational risks may increase. In the case of a multi-layered system, there would be fewer accounts and transactions to manage, and there would be fewer account management fees for the VSD. However, for the same reason, the operation risks may decrease.

For the SSC, as a supervisory institution, it would be possible under a mono-layered system to inspect on demand, the transactions and balance of each investor because all investors would have to open an account directly with VSD. It is also possible that the administrative burden of tax collection could decrease because all taxable accounts would be unified. However, the number of investors may increase with the development of the securities market, which would increase the number of accounts. This may increase monitoring costs such as personnel cost. This is because, there will always be a manual monitoring at the end of the line of monitoring process, regardless of introduction of excellent IT systems. On the other hand, monitoring each investor account managed by the custodians would be difficult in the case of a multi-layered system. However, it would make monitoring possible indirectly by enforcing reporting responsibility on the custodians.

(4) The Result of the Comprehensive Analysis

As the outcome of the comprehensive analysis, we reported the following three results:

- 1) Since the number of accounts opened at a depository under a multi-layered system is less than under a mono-layered system, there is less settlement risk involved in a multi-layered system.
- 2) Custodians can not participate in a mono-layered system, and that could become an impediment for cross-border transactions in the future.
- 3) Multi-layered system, under which investors can choose a custodian, can be said to meet more of international standards.

The number of investors and securities transactions is expected to increase as the securities market in Vietnam develops further. This means that under a mono layered system, the number of securities accounts newly opened at the VSD is the same as the numbers of investors increased and the settlement risk is to be brought about by the increased number of securities accounts and transactions.

Furthermore, the deregulation on foreign investment ownership cap could also bring about the increased number of foreign investors into the Vietnam securities market and the system which is more in line with international standard would be asked as the role of global custodian increases. In these standpoints, the TA team emphasized strongly that Vietnam adopts a multi layered system which has less risk and is more line with international standard, looking at the future development of securities market in Vietnam.

(5) Survey of Vietnamese Market Participants.

The TA team visited Ho Chi Minh City and Hanoi, accompanied by the SSC officials, from February 14 to 17, to conduct a survey among the securities market participants concerning securities account layered systems. The TA team visited nine financial institutions -- one trading center, one settlement bank, one global custodian, and six securities companies -- and obtained their answers to the questionnaire that we had sent beforehand. Please refer to the Chart 3 for the result of our survey.

Q1. Which type of market participants do you belong to?

Q2. Do you find any problem or inconvenience in double layered system which is currently adopted in Vietnam? If yes, please describe them specifically regarding the viewpoint as follows. (IT system, Operation, Cost and others)

Q3. Which type of securities account structures do you prefer to adopt at VSD, mono, double, or multi layered system? What are the reasons of your preference regarding the viewpoint as follows, (IT system, Operation, Cost and others)

Q4. Do you think that your preference which you answered in Q3 will have any influence on your IT system? If yes, please describe them specifically.

Chart 3

The Results of Market Interviews on the Layered Systems (Feb.14 - Feb.17 2006)

Executive Summary of the interviews	
<p>Q1. Which type of market participants do you belong to? Please check the box below.</p> <p>Central Securities Depository Securities Trading Center, Stock Exchange Custodian bank/Custodian Securities company Securities Company as a dealer Institutional Investor</p>	<p>Types of interviewees;</p> <p>1 Securities Trading Center (HOSTC) 1 designated bank 1 global custodian bank 6 securities companies (custodian banks and dealers)</p> <p>Total: 9 interviewees (4 in HCMC and 5 in Hanoi) Interviewer: IIMA and SSC</p>
<p>Q2. Do you find any problems or inconvenience in double-layered system which is adopted currently in Vietnam? If yes, please describe them specifically regarding the viewpoint below.</p> <p>IT system: Operation: Cost: Others:</p>	<p>Problems and inconvenience in current structure;</p> <ul style="list-style-type: none"> - Lack of electronic linkage between STC and depository members: 6 - Too many manual works are involved: 6 - Legal requirements to check clients' balance before placing orders cause burdens on securities companies: 3 - No substantial problems: 2 - Lack of human resources (including IT staffs) to catch up the too many manual works: 2 - Lack of IT capability on securities companies side: 1 - Present system can not accommodate trust business and shareholders' information such as ST code: 1 - Lack of standardization of services <p>HOSTC's comments;</p> <ol style="list-style-type: none"> 1) Difficulty to provide the shareholder books easily and timely because It is difficult for us to find each transaction activity in current structure. (It is difficult to find final securities holder and have to ask securities companies.) 2) Difficulty to supervise abnormal transactions and 5% rule. 3) Software for depository and clearing systems (FPT) and the one for Registrar (VDC) are incompatible. 4) IT systems in STC do not connect with other IT system of the participants. 5) Lack of support to educate our IT staffs.
<p>Q3. Which type of securities account structures do you prefer to adopt at VSD, mono, double or multi-layered? What are the reasons of your preference regarding the viewpoint below? IT system: Operation: Cost: Others:</p>	<p>Preference of layered system;</p> <ul style="list-style-type: none"> - Mono layered system: 2 (HOSTC and a bank) - Double layered system as current: 4 - Double or Multi layered system: 1 - Multi layered system: 1(a global custodian) - No idea: 1 <p>Total: 9</p>
<p>Q4. Do you think that your preference which you answered in Q3 will have any influence your IT system? If yes, Please describe them specifically.</p>	<p>Comments on IT system;</p> <ol style="list-style-type: none"> 1) In case of mono-layered system, building up a new united securities depository system is needed. (HOSTC) 2) Standard message format such as SWIFT should be introduced between depository and depository members in the future development. 3) They are now processing of introducing upgraded IT system by abolishing their old system bought from Hungary ten years ago. The choice of mono or multi is one of the important factors in designing a new system. They are now being offered from Malaysia
<p>Q5. Please write down any comments if you have.</p>	<p>Other comments;</p> <ul style="list-style-type: none"> - Importance of IT system development to fit the layered system which will be adopted - Establishment of electronic linkage between STC(VSD) and depository members - Importance of automation and standardization of operational procedures - Supports of cost sharing and IT education from VSD for the future IT development are expected. - If mono-layered is adopted, loss of opportunities for securities companies to earn interests by money deposit from clients has to be considered. - New system should be (a) automated (b) highly secured (c) with accurate information and (d) proper electronic linkage between VSD and depository members.

The TA team learned from the answers for Q2 that 90% of the respondents feel that there is a problem in the current system outside of the layered system issue itself. One of the problems they are alluding to is the lack of any electronic connection between the market participants and the securities trading centers, which means that there is a lot of manual works involved in the process from transaction to settlement. Another problem is that when a securities company places an order for a customer, the company has the legal obligation to check the balance of securities and funds on behalf of its customer, which places a considerable burden on market participants. Trading volume is expected to increase with the development of the Vietnamese securities market, and there were

doubts as to whether when trading does increase, it would be administratively possible to check the balances on the phone every time an order is placed. The global custodian noted that the current double-layered system would not be able to accommodate the trust business that Vietnam would be considering for the future.

As regards the choice of a layered system, most of the market participants did not find any problem with the layered system itself, and preferred the current double-layered system. The support comes partly from wanting to stick with something they are accustomed to. However, the global custodian commented, as expected, that it would be better to choose a multi-layered system in view of the development of the securities market and the increase in transaction volume.

(6) The Aspects that Vietnam should consider when choosing a layered system

Based on the comprehensive analysis of layered systems and views expressed in the market survey, the TA team suggested the following three points as those that should be considered when Vietnam chooses a layered system.

- 1) The government has first to clarify what the first priority is in the layered system.
- 2) Regardless of the layered system that would be chosen, a high-quality IT system must be developed for VSD.
- 3) Information and knowledge concerning the layered systems and the related IT system must be shared with all market participants.

First, the TA team pointed out the importance of clarifying the first priority in selecting a layered system. Is it for the supervising ministry to be able to inspect the balance of all transactions in a timely manner by having all market participants open an account at the VSD, even if it would be costly to change from the current system? Or is it to create a more efficient system that would be more attractive to foreign investors with an eye to globalizing the securities market in the future? Whatever the objectives, they must be made clear. Then the current situation and the ideal situation in the future must be checked against the pros and cons to choose the most suitable system.

Second, the TA team emphasized the importance of developing both the IT system for the VSD and the system that would connect the VSD and the market participants regardless of the type of layered system that is chosen. Since there is no electronic connection between the securities companies and the securities trading centers, there are a lot of manual works on both sides in the course of the administrative flow from transaction to settlement in the securities market, making the

whole procedure extremely inefficient. As most of the works are dependent on human judgement and manual labor, there are considerable amount of administrative risks as well. It was made clear in the survey of market participants that their gravest concern was to enable a smoother and more efficient communication with the securities trading centers by systematizing as much of the works as possible throughout the administrative flow from transaction to settlement. Hence, it is critical to develop an IT system that would manage the layered system as efficiently as possible regardless of whether the current system is continued or a new system is adopted. Choosing something like a SWIFT system which is a standardized format in order to standardize operations is one choice to consider. SWIFT would also make a huge contribution when creating a link with the securities depositories of other countries.

Third, we underlined the importance of sharing the information on the layered systems that the government is considering and on the related IT system as the future layered system is examined. The market participants in Vietnam lack knowledge on layered systems or IT systems. Under these circumstances, it would create only confusion if the government decides on the layered system by itself and tries to push the development of the related IT system. In order to avoid confusion and to choose the layered system that best suits the Vietnamese securities market, market participants, too, must acquire knowledge and understanding of the structure that the government is considering, and the government must absorb what market participants need. This does not mean to say that the government has to reflect all the demands of the market participants in its decision. But it is important that the public and the private sectors move the reform forward together in order to meet the big objective. The TA team again proposed the creation of a PMC as a place for exchange of views between the public and private sectors. Such a framework could significantly contribute not only to the establishment of the VSD but also to the overall reform of the Vietnamese securities market.

(7) Issues for the Future

The TA team held a workshop on securities account layer systems on March 2 for about 30 members of SSC and VSD officials. The TA team reported on the general concept and analysis of layered systems and the results of the market survey. The WG member explained the framework of the current double-layered system and introduced the Malaysian model which is one of the systems under consideration. The TA team could not assess if the Malaysian model could be one of the recommendation which Vietnam should adopt, with only the information given in the workshop. For that reason, the TA team asked Vietnam side to keep researching on the model to find out if that is appropriate for Vietnam, based on the general analysis and some recommendations made by the

TA team.

One of the senior levels from the SSC commented at the end of the workshop that it is important to consider the best system for Vietnam with the balance of the contribution to the market and the investment costs for the change of the layered system, and that there were many issues that still had to be discussed domestically. The VSD's initial objectives for changing the layered system from the current one seemed to be to supervise the transaction and balance of all the participants. However, the comments made by the SSC which pointed out the importance of the contribution to the market as well as the investment cost, could be evaluated positively. In addition, it was invaluable to hold the workshop from an educational standpoint since the members of the SSC and the VSD, who are the policy makers of the securities market, as well as the WG members were able to gather at one place and share their concerns.

A guideline based on the planned new Securities Law is expected to regulate the layered system that will be adopted. However, it is critical to first lay out clear objectives concerning what kind of a securities market the Vietnamese government is aiming for. The development of the IT system on the one hand and at the other the Securities Law and various regulations that would enable the market participants to be involved in investment activities with confidence are like the two wheels that will effect the achievement of those goals.

Chapter 3: Development of the law on securities settlement

1. Outline of this Chapter

A WG was formed by officials from SSC and of HASTC in the FY2004 TA to review and discuss the bill on securities settlement, issue by issue, with the TA team. The TA team exchanged ideas and gave advice based on the Japanese experience. The results were fed back to relevant government officials including the VMOF in a seminar on March 11 2005.

This fiscal year, the TA team conducted hearing on the process for implementation of the securities law. The TA team also compared the 7th draft of Securities Law which was submitted to the Standing Committee in January 2006, with 4th draft which the TA team reviewed last fiscal year. The results of the comparison were fed back to the SSC in middle of February 2006.

Before making comments and recommendations on the 7th draft of Vietnam Securities Law, the TA team made an observation on the draft from the perspectives and the criteria described below.

(Perspective and criteria to review the draft)

- 1) We focus only on Chapter V “Securities Registration, Depository, Clearing and Settlement”
- 2) We compare this 7th draft with the 4th draft which we examined in the project of last fiscal year, and
- 3) We evaluate how far the discussion we made in last fiscal year was reflected in the 7th draft

2. Process for enacting the securities law

The TA team conducted hearing with Legal Dept. of the SSC on the regal structure in Vietnam and the process to the implementation of the securities law. The results are as follows.

The Securities Law described in this report correspond to the 2) Law below.

(Regal structure in Vietnam)

- 1) Constitution (“Hien Phap” to be approved by National Assembly)
- 2) Law (“Luat” to be approved by National Assembly)
- 3) Ordinance (“Phap Lenh” to be approved by Standing Committee of National Assembly but not

applicable for securities market activities)

- 4) Decree (“ Nghi Dinh” to be approved by Prime Minister = Government)
- 5) Regulation/Circular (“Quyche”/”Thong Tu” to be approved by Minister of Finance in the case of Securities Law)
- 6) Guideline/Rule (“Huong Dan”/”Quy dinh” to be approved by Chairman of SSC in the case of Securities Law)

(Process for enacting the securities law)

1. Official documents with regard to the securities market activities to be promulgated are the Securities Law, Decree, Regulation and Guideline which are drafted by representatives from SSC and other relevant organizations and approved by the competent ministers.
2. In 2002, the proposal to start drafting Securities Law and the relevant concept paper were drafted and submitted to the Standing Committee by the VMOF and the SSC, which was approved in early 2003.
3. Each competent department is responsible for drafting the relating chapter of concept paper of the Securities Law.
4. After obtaining the approval from the Standing Committee, a drafting team was formed, which consists of 21 officials representing the SSC (Personnel Dept., Issuance Dept., Market Development Dept., Securities Management Dept. and Surveillance Dept.), the VMOF (Legal Dept. and Financing Banking Dept), the MPI, the HASTC and the HOSTC.
5. In April and July 2005, workshops of the Securities Law were held for market participants and 4th and 5th drafts were distributed to them. The drafts were also published on the SSC’s website in Vietnamese. A survey was also conducted to find the needs of the law among market participants.
6. In January 2006, the 7th draft which is considered to be the final version at SSC’s level was submitted to the Standing Committee to be approved, though still subject to modification.
7. From March to May 2006, three workshops are going to be held in Hanoi, the middle part, and HCMC for the Provincial National Assemblies for explaining the contents of the law.
8. In May 2006, The final draft of the Securities Law is going to be approved at the general meeting of the National Assembly, together with decree.
9. From January 2007, the law is going to be implemented. By that time, regulations and rule are also going to be prepared.

3. The results of review on 4th draft of the securities law chapter 5 in last fiscal year

In FY2004, the TA team reviewed 4th draft of the securities law, focusing on Chapter 5 which describes securities depository. The problems were pointed out through the perspective of the Japanese Corporate Bond Transfer Law. The problems that we saw from the overall review were as follows.

- <1> There are numerous regulations on depository members but not enough on the VSD itself.
(Rules and regulations might be necessary in case the operation mistakes happen in the VSD.)
- <2> Is it not preferable to apply details regulations following international standards for articles that directly and tremendously affect the interests of the participants such as ownership, transfer and finality of securities, about which the participants are most interested as the VSD conducts its operation?
- <3> The VSD's structural entity is as yet undecided. There will be contradictions concerning whether it aims for profit if it is a joint stock company or a limited liability company and yet at the same time a non-profit organization. This contradiction should be resolved.
- <4> Should the VSD not have the obligation to write a business plan and a report?
- <5> In case the VSD brings loss to the participants that leads to insolvency (though this is very unlikely), should there not be a rule on the protection of investors?
- <6> There have been discussions on whether to have a single-stage structure where the users open their account only at the VSD or to have a multi-layer structure where only the depository members and major financial institutions open their account at the VSD and the other users open theirs at a depository member or a financial institution that has an account at a depository member. The SSC has suggested a mixed model where all users can choose between opening an account at the VSD or at a depository member. Should the law not be revised to clear the problems, for example whether it would be affected by the existence of a trust law, which legally protects the profits of the consignor?

4. The results of comparison of 7th draft of the securities law with 4th draft in this fiscal year

In FY2005, TA team compared the 7th draft of Securities Law which was submitted to the Standing Committee in January 2006, with 4th draft which the TA team reviewed last fiscal year. The results of comparison were fed back to the SSC.

<The Articles newly added>

Article 38. An application file for a license for securities depository operations

An application file for a license for securities depository operations shall include:

1. an application for a license to carry out securities depository operations ;
2. legitimate supporting documents that the securities company or the commercial bank has fully met those requirements set out in Article 37 hereof.

Article 41. Transfer of securities ownership

1. The transfer of securities ownership with respect to those securities which have been registered at the Securities Depository Center shall be undertaken via Securities Depository Center;
2. The transfer of securities ownership of companies having its securities registered at a Securities Depository Center shall be valid on the date of making book-entries in the securities registration accounts of the Securities Depository Center.

Article 43. Protection of depositor property

1. Any securities, whether tangible or intangible, and other assets of customers held by a Securities Depository Center or relevant depository members shall be the property of the depositor and shall not be considered as a part of the assets of the Securities Depository Center, or depository members authorized by customers.
2. If a Securities Depository Center or depository members are declared bankrupt or insolvent in accordance with the law, such securities of the Securities Depository Center or the depository members may not be used to repay any debts to each other or to the creditors of the others. This provision shall not apply where securities have been pledged or mortgaged under another specific agreement.

Article 44. Secret-keeping

Securities Depository Center, depository members shall take the responsibility to keep secret the information regarding securities ownership of customers, except the cases of information disclosure upon the requirement of authorities in compliance with regulations of the laws.

<The Article eliminated>

Article 45. License revocation

A depository license shall be revoked in the following cases:

- a. The depository member does not operate after 12 months from the date of the depository license.
- b. Ceasing its operation at its own discretion;
- c. Due to the depository member's dissolvent, bankruptcy, annex, mergence, separation, acquisition...
- d. A branch of foreign banks being depository member may cease its securities depository due to the dissolvent, bankruptcy, annex, mergence, separation, acquisition...of its own or of its mother bank.

Article 46. Deposited securities

The VSD undertakes depository and custody of the following classes of securities:

Listed securities and trading registered securities on Stocks Exchange or Securities Trading Centers

Other securities if required by the issuer.

These are the articles which are newly added and eliminated we understand in comparison with 4th draft and 7th draft.

As for the problem <1> mentioned above, the TA team again suggested the SSC the consideration of contingency plans against erroneous records made by the VSD or depository members.

Legal Dept. of the SSC commented that they would take this suggestion into account as one of the issues to be discussed.

As for <2>, the definitions of ownership, transfer and finality of securities are clarified in the Article 41.

As for <3> VSD's structural entity, the contradiction was solved by eliminating the statement "non-profit organization". In the 7th draft, the Article for the rights of VSD and the duties of VSD are stipulated separately.

As for <4> VSD's obligation to write a business plan and a report, it is clearly defined to some extend by stating "To comply with accounting, statistic reporting and information disclosure requirements in accordance with the law" in Article 35 Duties of a Securities Depository Center.

As for <5> a rule on the protection of investors in insolvency, the statements for the protection of depository property and the treatment of the property in insolvency are newly added. However, the TA team recommended a formation of specific framework for the protection of investors. The Legal Dept. of SSC is considering the establishment of another fund, which is different from Joint Compensation Fund (JCF), regarding the specific framework for the protection of investors.

As for <6> layered system, the choice by the government is not yet made as described in Chapter 2-3, and the issue is not stipulated in the Securities Law. It is going to be stipulated in the Regulation in the future, according to SSC.

The reason that the statement of the limitation of deposited securities at the VSD has been eliminated could be that the VSD is going to take OTC market into account for the future. There is a possibility that the service by the VSD could include not only the listed securities but also unlisted ones.

The TA team pointed out that DVP in line with international standard is not introduced in Vietnam although it is stated in Article 45 “The settlement of securities shall be conducted via Securities Depository Center, the cash payment shall be conducted via settlement banks, and pursuant to the delivery-versus-payment principle.” The fund settlement and securities settlement are conducted at different institutions currently and these are no electronic connection between those. As regards this point, SSC understands that it is one of the issues to be considered for further development.

The TA team recommends that the spirit of the coming Securities Law should be shared among market participants. In this regard, since its is difficult to stipulate all the activities and the relevant regulations, which could come out in the future, in the law at this moment, it would be necessary that Vietnam Securities Law will be reviewed periodically to respond to any changes and development of securities market in the future.

Chapter 4: Conclusion

In the current situation in Vietnam, trading, settlement and depository of listed securities are conducted at both of the HASTC and the HOSTC, but independently. In July 2005, the Prime Minister signed the Decision to establish a single depository in Vietnam, i.e. the Vietnam Securities Depository. In the Securities Law that is currently being drafted, the functions and the roles of the VSD are clearly stipulated. The Securities Law is to be submitted to the National Assembly in May 2006, passed in November 2006, and promulgated in January 2007. The VSD is planned to begin its operation in May 2006, initially as a lower organization of the SSC from 2006 to 2009, then to become either a joint stock company or a limited company and to be operated as an independent securities depository in 2009.

Three stages are envisioned in the development of the settlement system for the VSD. The first stage is a period in which the systems at the HASTC and the HOSTC are to be used separately as they are currently. The second stage is the one in which the two existing systems are to be integrated and used temporarily. The third stage is the one in which a completely new settlement system is to be adopted with the timing of VSD's becoming an independent securities depository.

As mentioned in chapter 2, the FY2005 TA was involved in the designing of the integration plan of the systems for the second stage, and in the IT system development plan for the third stage.

1. Summary of this year's TA

Concerning the integration plan of the systems at the HASTC and the HOSTC, the Vietnamese authorities requested that the change from the current structure, such as personnel and systems, should be as little as possible. The TA team took that into consideration and suggested connecting the two systems of the trading centers with a network of electronic circuits and to have data mirroring to establish a back-up system for each other. The SCC is expected to begin concrete examination of network building with local IT vendors, and further assistance is not expected on this issue.

Regarding the development plan of a new system which is to be adopted in 2009, the TA team proposed the establishment of a PMC, where the public and the private sectors can work together towards the reform in securities settlement system by prioritizing the functions to be installed under a realistic schedule. With the PMC taking the lead in reforming the securities settlement system, it is prerequisite for Vietnam to make a mid- and long-term development plan as a practical roadmap to achieve the securities market Vietnam pursues, in advance of drawing the IT system development

plan. Regarding the formation and running of the PMC, the transfer of know-how from Japan would be helpful for Vietnam.

The choice of securities account layered system is also an important issue that conditions the development plan of the new system which is expected to be adopted after 2009. The TA team provided the general analysis of pros and cons on the choice of a mono and a multi-layered system and necessary information for Vietnam in selecting the system. Considering Vietnam's securities market development in the future and how the system should be in line with the international standards, the TA team advised strongly that multi-layered system is more preferable. The TA team also conducted market survey on the layered system issue and fed back the results at the workshop. There was also a presentation by the WG on the current layered system and the Malaysian model which is under investigation as an option for the model of Vietnam. We believe that the basic information and knowledge on layered system issue could be shared among the SSC and the VSD staffs by the presentation from the TA team and WG.

It is preferable that information and knowledge on what the layered system is and which is suitable for Vietnam are shared not only among government staffs but also other market participants.

The points like whether the layered system which Vietnam adopts in VSD is suitable, and whether it is highly efficient, comparing with the investment cost, are expected to be discussed further in Vietnam from the perspective of cost-benefit performance.

2. The importance of making a blueprint

The existence of a blueprint for Vietnam's bond market development in mid- and long- term is crucial for conducting TA.

The Vietnam government's vision for the size and the content of the government bond market and its schedule of the introductions of primary dealer, the OTC market and new transactions as repo market are needed to be clarified with priority in that blueprint. The action plan to achieve the goals is also needed to be specified.

The blueprint is needed to be evaluated comprehensively in the view point of that whether each action plan indicated in the blueprint is in appropriate sequence, and planned as realistic schedule and so forth.

TA team, closely together with JMOF repeated at every occasion how important it is for the VMOF to write a blueprint for the government bond market on its own initiative. The team understands that the VMOF is addressing the issue of blueprint.

3. The requests from Vietnam with regard to future TAs

(1) The VMOF and the SSC requested that next year's TA to be started as soon as possible and in this regard, the following requests for next year's TA have been presented by the SSC at the conclusion of this year's TA activities.

1 . Objectives:

Developing the registration, depository, clearing and settlement for the following bonds and debt instruments in order to accomplish the bond transaction market by building the efficient linkage between the securities market and the currency market from the IPO to the secondary transaction:

- Government bonds; (first priority)
- Corporate bonds;
- Other debt instruments;

2 . Details:

VSD will be in charge of the functions of registration, depository, clearing and settlement for the bond transactions on the central market and the OTC market.

3 . Requirements:

- Advising of the detailed functions of the VSD in the performances of the bond issuance on the primary market and bond transactions on the central as well as OTC secondary markets (including the linkages with the currency market in operating the open market):
 - o managing registration for new issued bond's ownership;
 - o bonds depository;
 - o transaction clearing and settlement;
 - o performing owner's rights;
- Designing the VSD's system to serve the above mentioned functions.

(2) We have been focusing on IT system development for the securities in general traded at the STCs as a part of the establishment of the infrastructure for Vietnam securities market. According to the requests from Vietnam, the scope of the service by VSD is expanded to the OTC market from the STCs, while the TA's scope of securities is focused on bonds, as written "Government bonds; (first priority)"

This recalls that the article which stipulated the limitation of deposited securities in the 4th draft of the Securities Law has been eliminated in the 7th draft, taking the establishment of the OTC

market in the future into account. Additionally, this seems to have a relation with a discussion which is likely to be started for the unification of bond management from registration to settlement at the VSD including the bonds issued through the SBV and the State Treasury, to improve the current inefficient management.

(3) Those requests from Vietnam are required to be in line with the blueprint mentioned in 2. The requests are needed to be well evaluated from the view point of how the requests are included in the blueprint and whether the projects given in the requests should be conducted at this timing.

In this regard, the requests given by the Vietnam side this time could be said as an extension of what have been done in the past TAs, and could be evaluated favourably for its importance and necessity.

However, it is necessary to consider it together with the blueprint to make a final decision on whether it should be conducted in FY2006 TA, especially whether it is the TA which Japanese government should conduct by priority.

Appendix

Appnedix 1

Overall activities for the Technical Assistance to Vietnam on the Establishment of Vietnam Securities Depository, commissioned by Ministry of Finance Japan

Month	day	Activities	Details	Requests from Vietnam	Requests from Japan	Agreement
8	5 -				The contents of TA; 1) To design a new system for the bond settlement at VSD 2) To follow-up on the process leading to the finalization of the Securities Law	
				The contents of TA; 1) Integration of the systems at HASTC and HOSTC 2) Adoption of new system for VSD		
	7 ~ 13	1st trip to Vietnam	Visited VMOF,SSC			The contents of TA; 1) Proposal on the integration of systems at HASTC and HOSTC 2) Comprehensive analysis on the effect of choosing a mono-layered system for the new system
			Visited HASTC		Operation manual of HASTC	
			Visited SSC	Preliminary request to host the mission for studying securities market in Japan		
	14	Received operation manual from HASTC (Vietnamese)				
	22	Report to JMOF	by Email			
	24	Received operation manual from HASTC (English)				
	27	Questionnaire to SSC	Objectives and policies for the integration			To receive the answers by Aug.30
29	Report to JMOF	Meeting; the contents of TA and how to proceed with				

Month	day	Activities	Details	Requests from Vietnam	Requests from Japan	Agreement	Supplement
9	12	Letter to VMOF	The contents of TA				
	22	Material to VMOF	Tentative schedule				
10	11 ~ 15	2nd trip to Vietnam	Visited SSC	To include the recommendation of layered system Vietnam should adopt	It is difficult to design system under the situation in which layered system is undecided	The contents of TA; 1) Proposal on the integration of systems at HASTC and HOSTC 2) Comprehensive analysis on layered system 3) Support VSD to draw the medium to long-term IT development plan at VSD	Agreement on the contents of TA (changed from August)
					Operation manual of HOSTC		
	16	Received answers from SSC	Received answers for the questionnaire we submitted in August				
	17	Report to JMOF	Meeting: the agreement on the contents of TA in 2nd trip				
	18	Received operation manual from HOSTC (Vietnamese)		To make official TA proposal			The local consultant mentioned the necessity of TA proposal
11	10/30 ~ 5	3rd trip	Visited VMOF, SSC Submitted TA proposal	SSC's Requests on the schedule of TA 1) System integration (from Nov. to early Dec.) 2) Layered system (from Feb.) 3) IT development plan (from mid Dec. to Jan.)		To conduct TA based on the schedule SSC requested To hold workshop at the end of each theme of TA	Agreement on the schedule of TA
	2	Received operation manual from HOSTC (English)					
	7 ~ 11	Study tour to Japan	9 mission visited Japan				
	17	Submitted flow charts of HASTC	Submitted flow charts of HASTC made based on the manual received in				
	20 ~ 12/19	4th trip to Vietnam	Visited SSC (22) Formed WG (29) Visited HASTC (30)				
21	Submitted flow charts of HOSTC	Submitted flow charts of HOSTC made based on the manual received in October					

Month	day	Activities	Details	Requests from Vietnam	Requests from Japan	Agreement
12	1	4th trip to Vietnam (continued from Nov.)	Visited HOSTC			
	12	Preliminary proposal	Submitted preliminary proposal to WG for system integration			
	16 ~ 15	WG activities	Discussion with WG			<ul style="list-style-type: none"> Final proposal on system integration To start discussion on IT development plan in Jan. To hold workshops for system integration and IT development
	22	Report to JMOF	Meeting: the agreement and activities in 4th trip			
1	18 ~ 12	5th trip to Vietnam	Discussion for IT development plan			
	12	Workshop	on system integration			
	13	Workshop	on IT development plan			
		SSC		<ul style="list-style-type: none"> To send an official letter to SSC for the cooperation in market survey for layered system in advance To comment on 7th draft of Securities Law 		<ul style="list-style-type: none"> To hold a workshop for layered system issue in Feb. To send an official letter to SSC for the cooperation in market survey for layered system in advance To comment on 7th draft of
	26	Official letter for market survey	Sent an official letter to SSC for the cooperation in market survey			
	27	Questionnaire to SSC	Submitted a questionnaire for market			
	31	Report to JMOF	Meeting: the agreement and activities in 5th trip			
2	16	SSC's comments	Submitted the comments on 7th draft of Securities Law			
	13 ~ 3/4	6th trip to Vietnam				
	2/14 ~ 17	Market survey	at Ho Chi Minh City and Hanoi			
	20 ~ 3/1	WG activities	Discussion with WG			To hold a workshop in March 2
3	2	Workshop	on Layered system			
	9	Report to JMOF	by Email: the results of 6th trip			
	14	Request from SSC	Received request for the future TA	Advising on the function of VSD in the performance of the central market as well as the OTC market and designing the system		
	24	Submitted final TA report				

The Procedures for Settlement on the basis of Bilateral Clearing @ Hanoi Securities Trading Centre (HASTC)

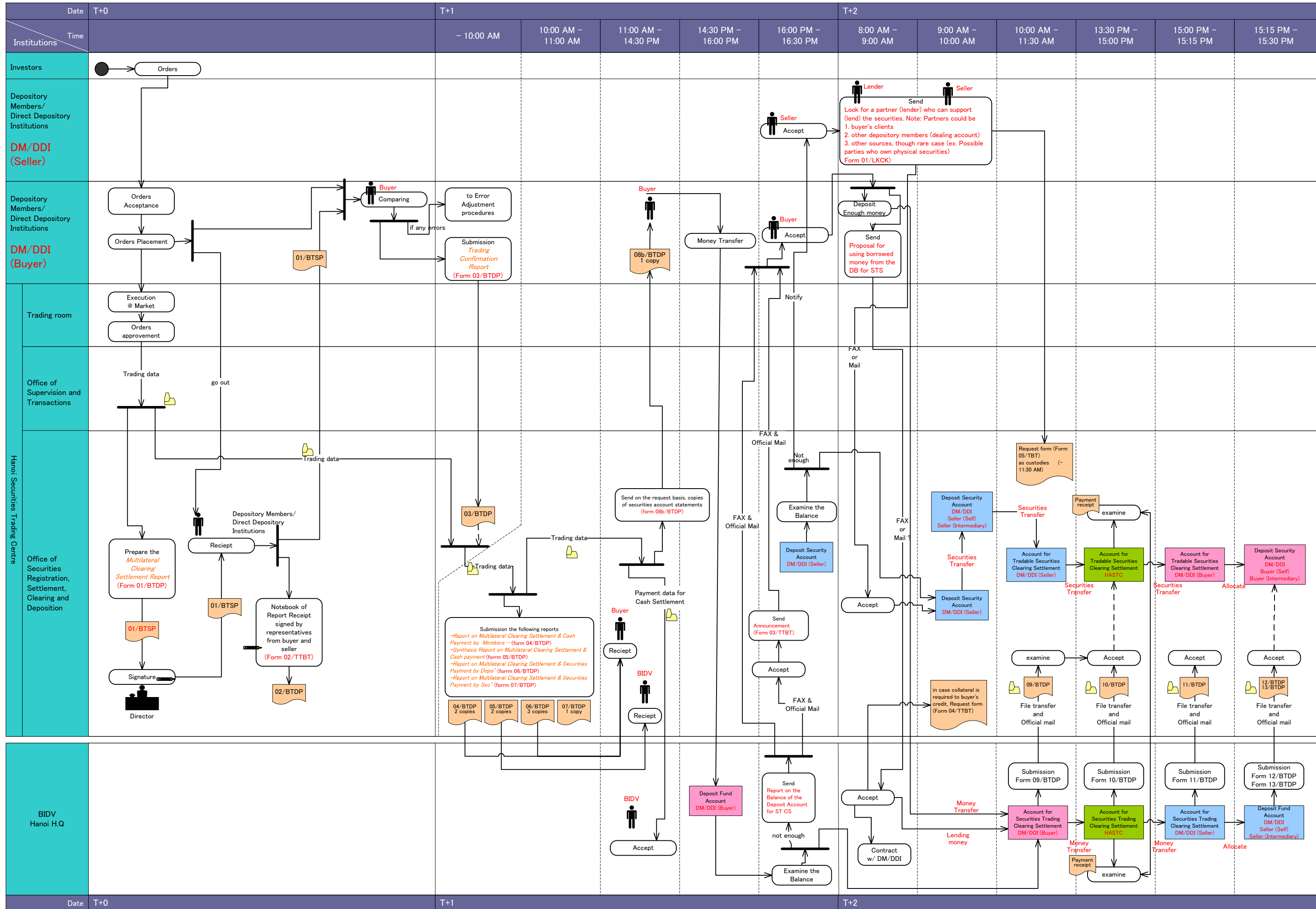

The Procedures for Settlement on the basis of Multilateral Clearing (T+3) @ Hanoi Securities Trading Centre (HASTC)

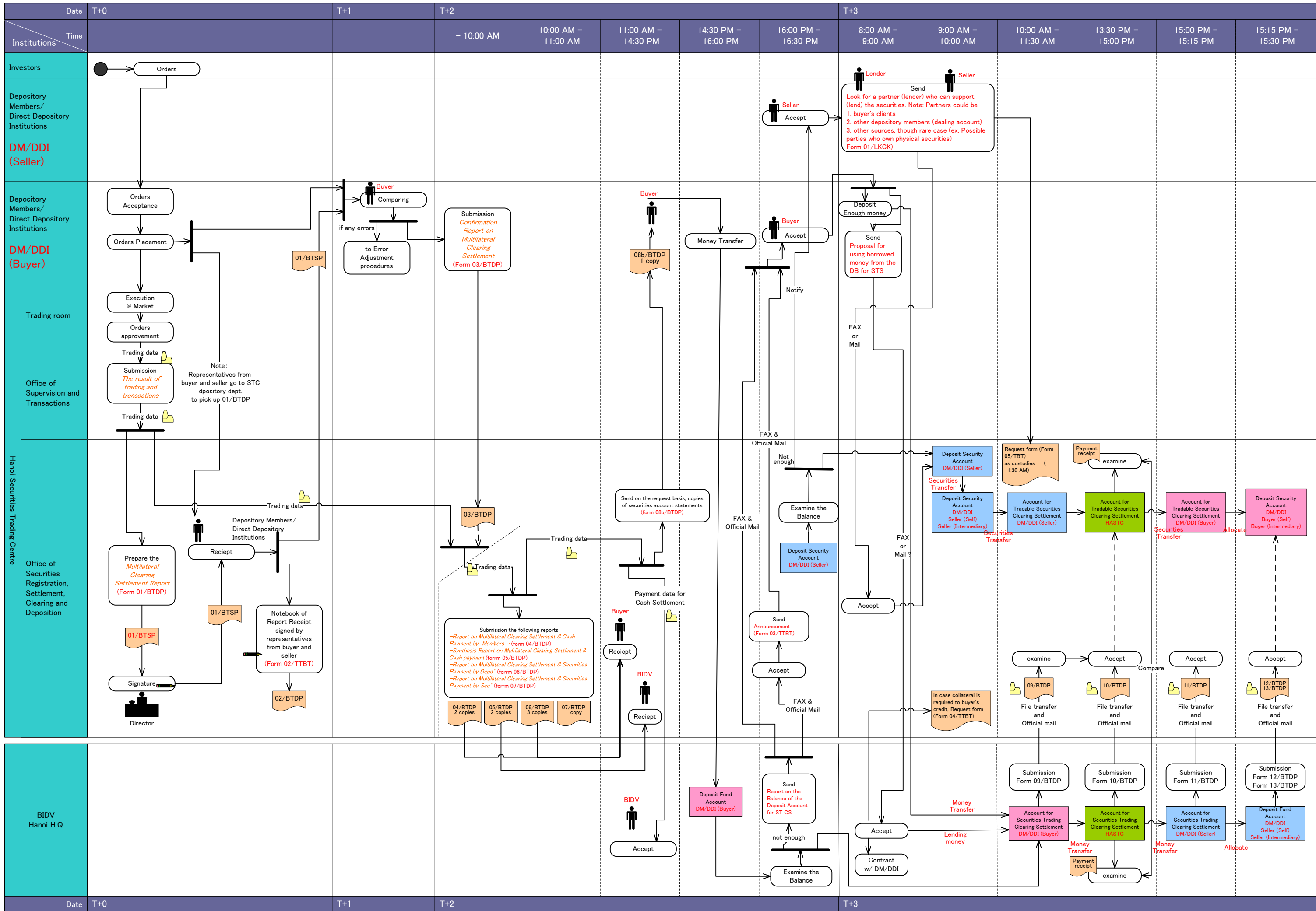

The Procedures for Direct Settlement @ Hanoi Securities Trading Centre (HASTC)

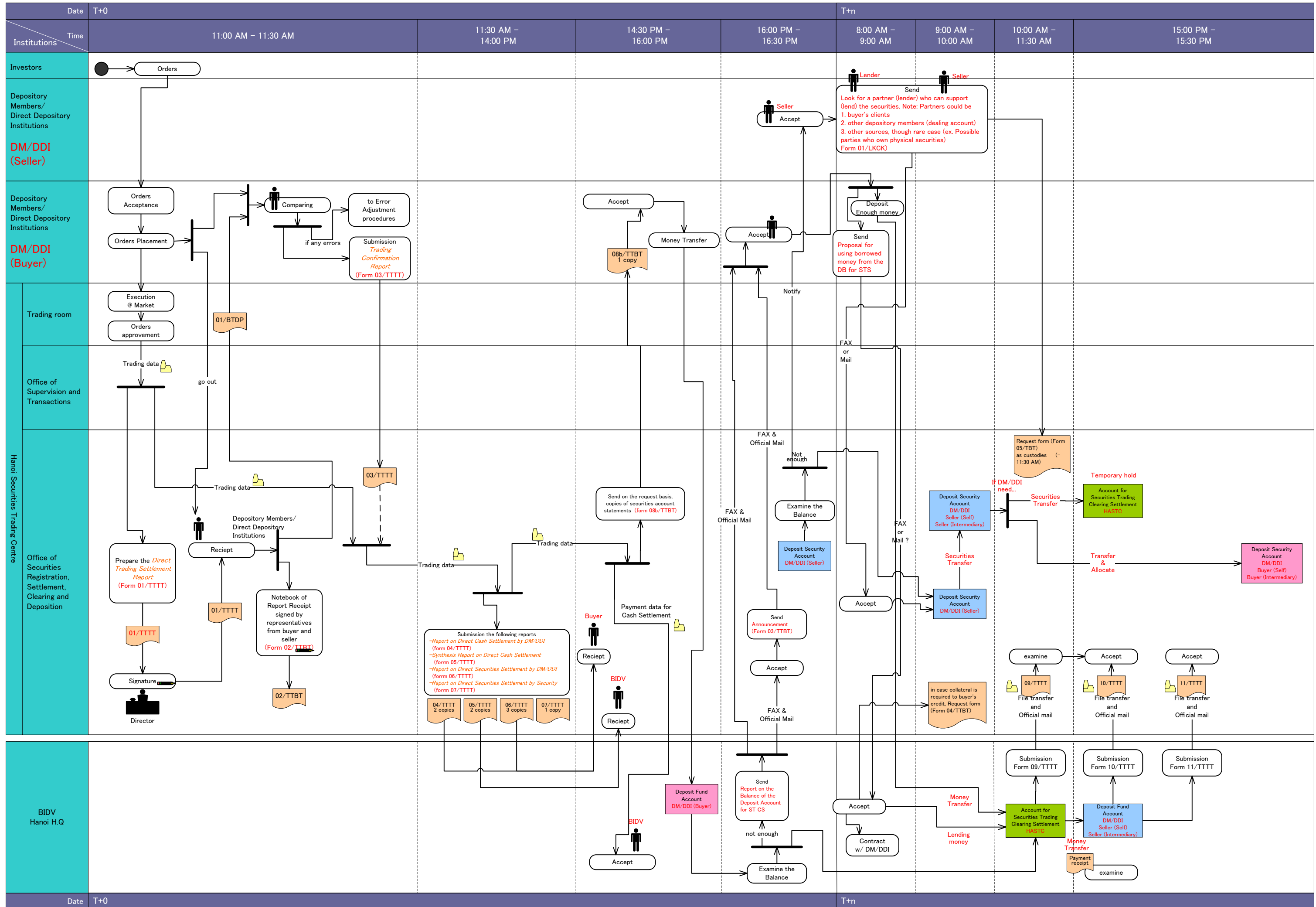

The Procedures for Settlement on the basis of Multilateral Clearing @ Ho Chi Minh City Securities Trading Centre (HOSTC) T+1

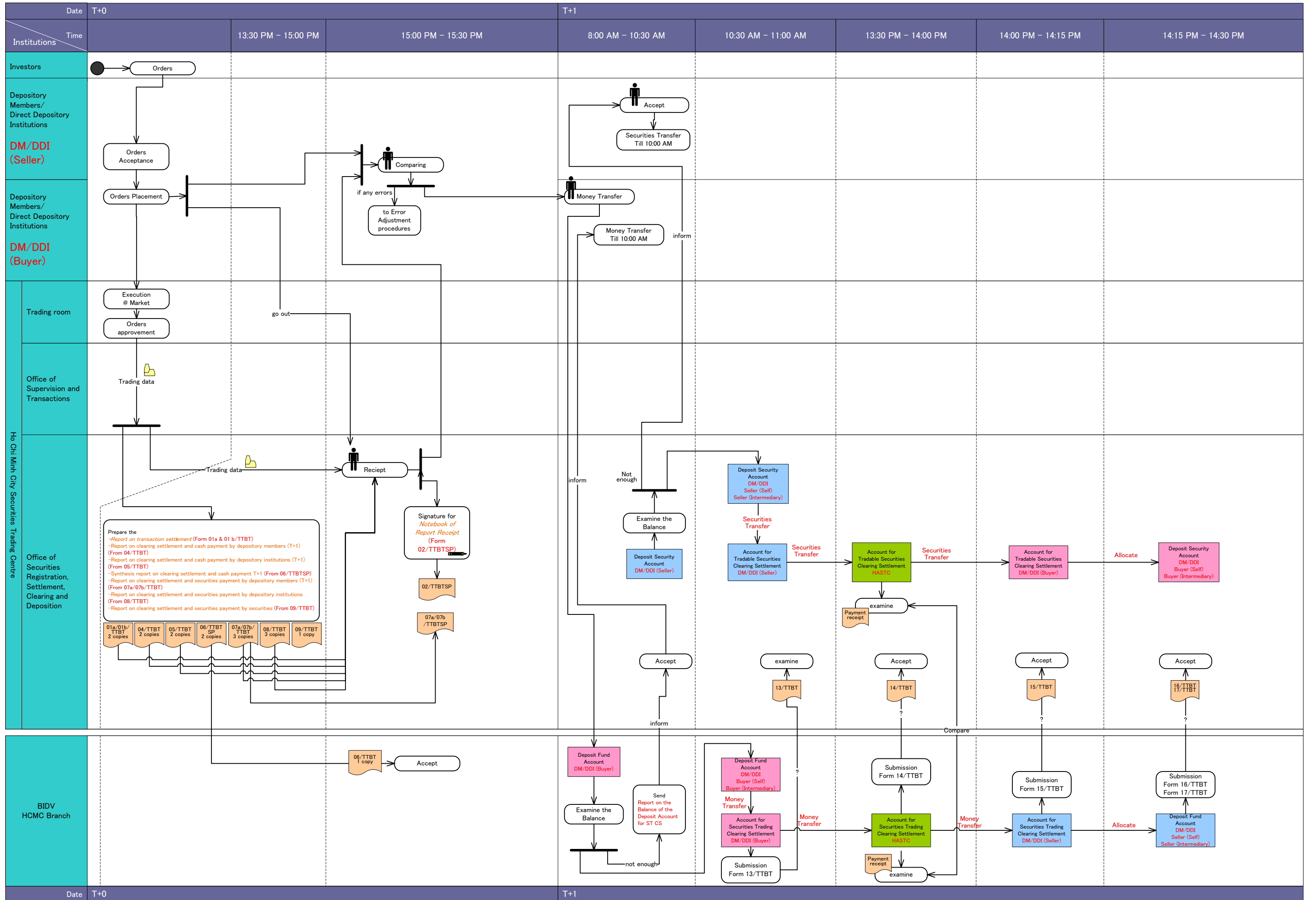

The Procedures for Settlement on the basis of Multilateral Clearing @ Ho Chi Minh City Securities Trading Centre (HOSTC)

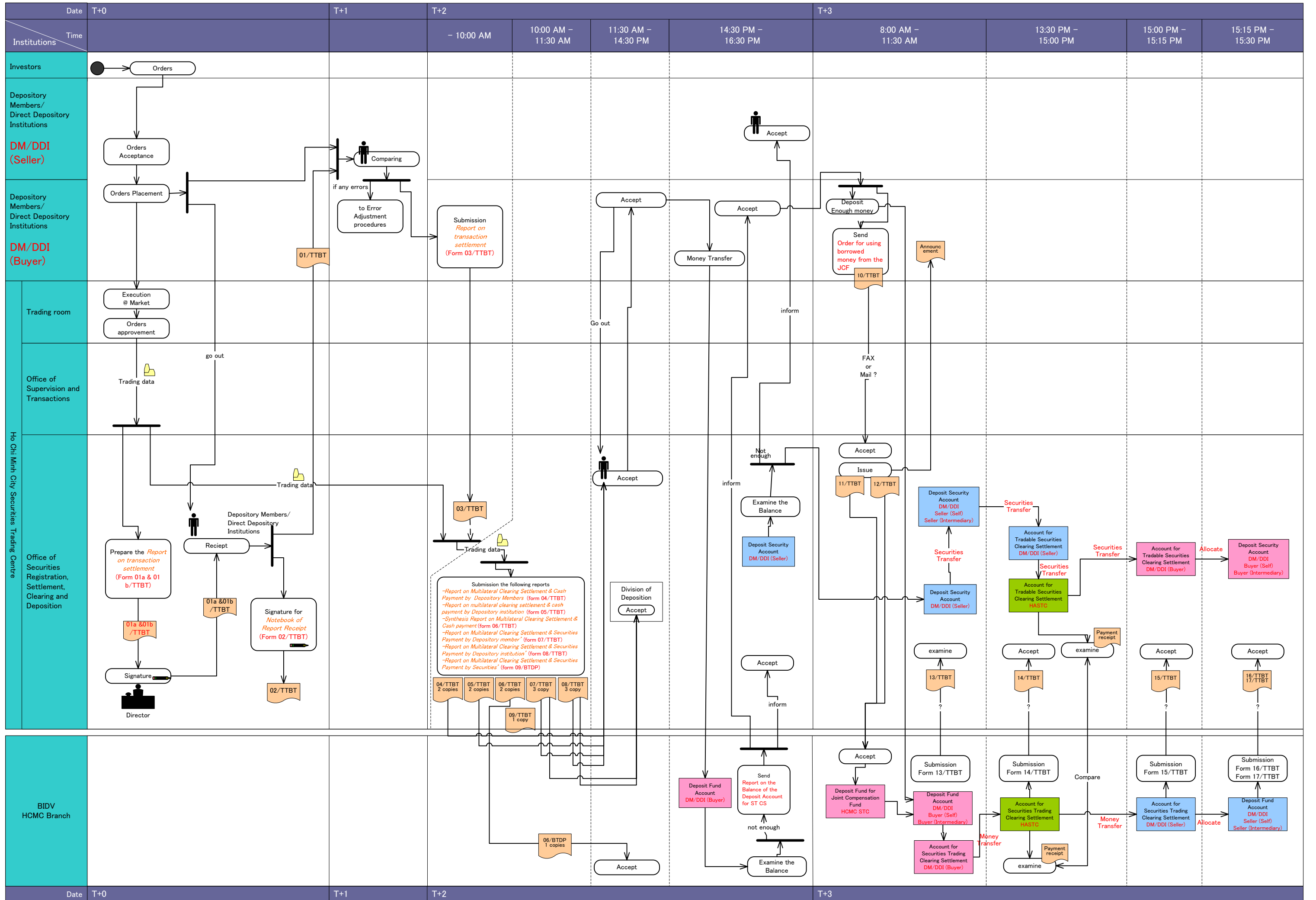

Ordinary Operation

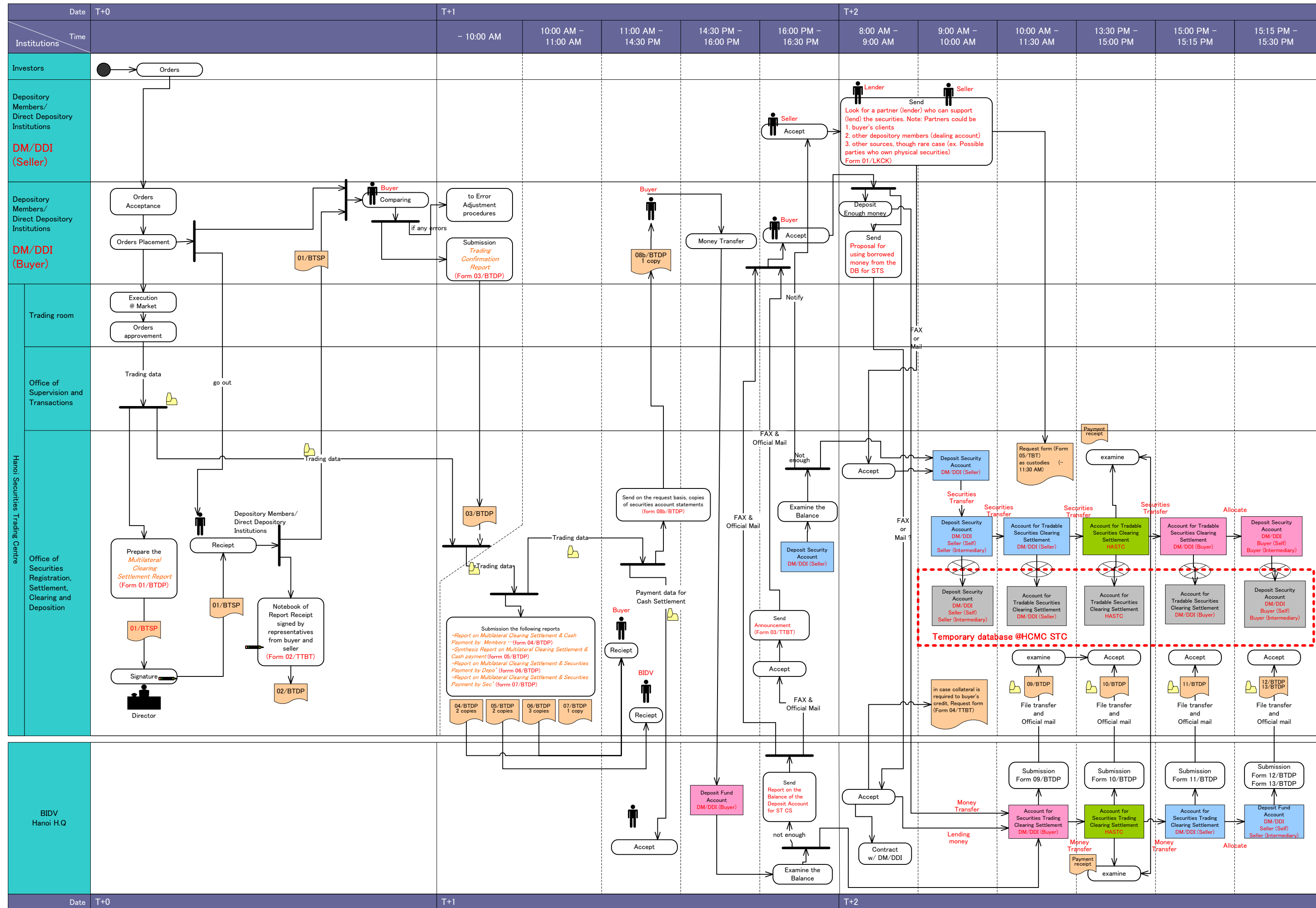

The Procedures for Settlement on the basis of Multilateral Clearing (T+3) @ Hanoi Securities Trading Centre (HASTC)

Ordinary Operation

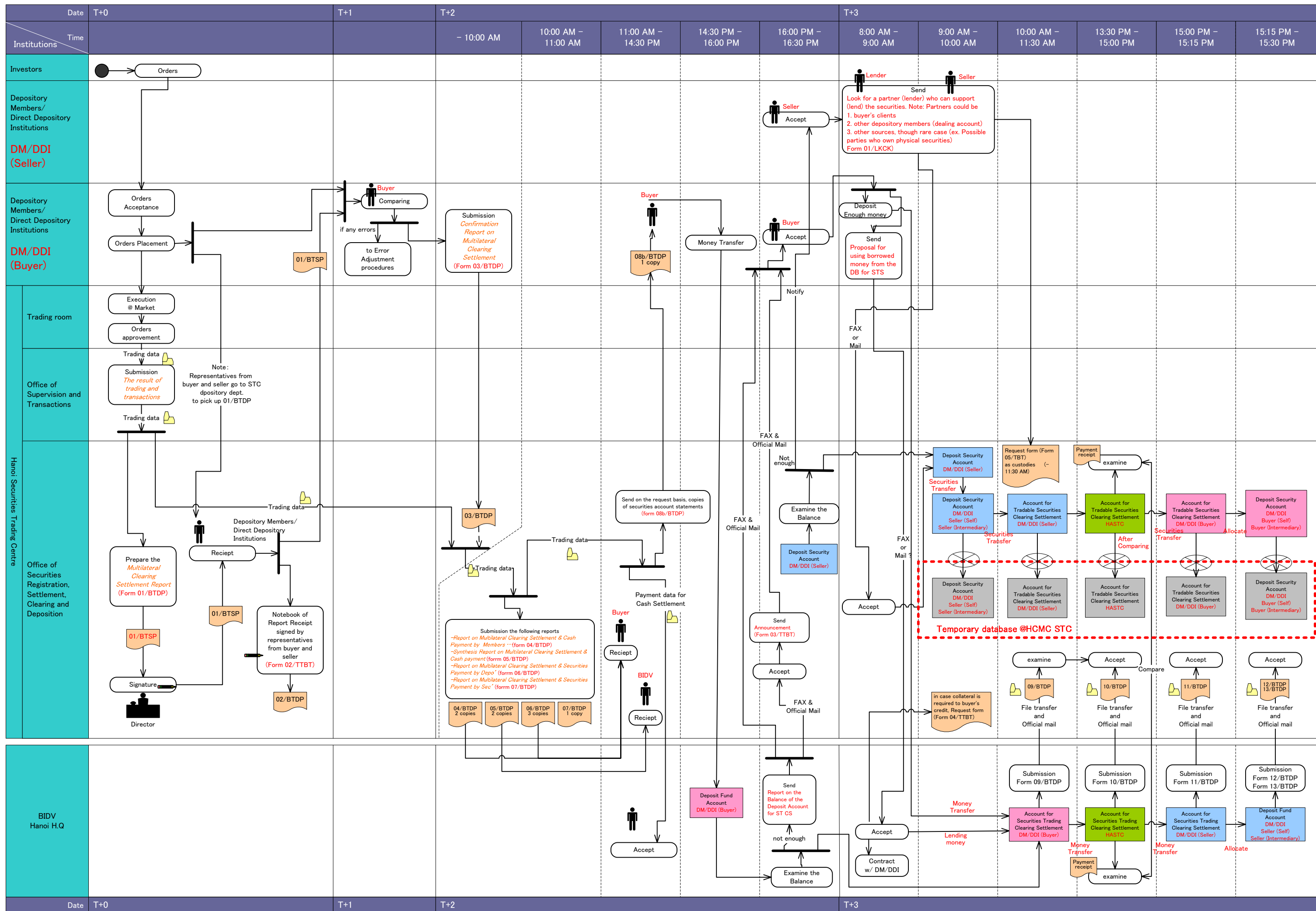

The Procedures for Direct Settlement @ Hanoi Securities Trading Centre (HASTC)
Ordinary Operation

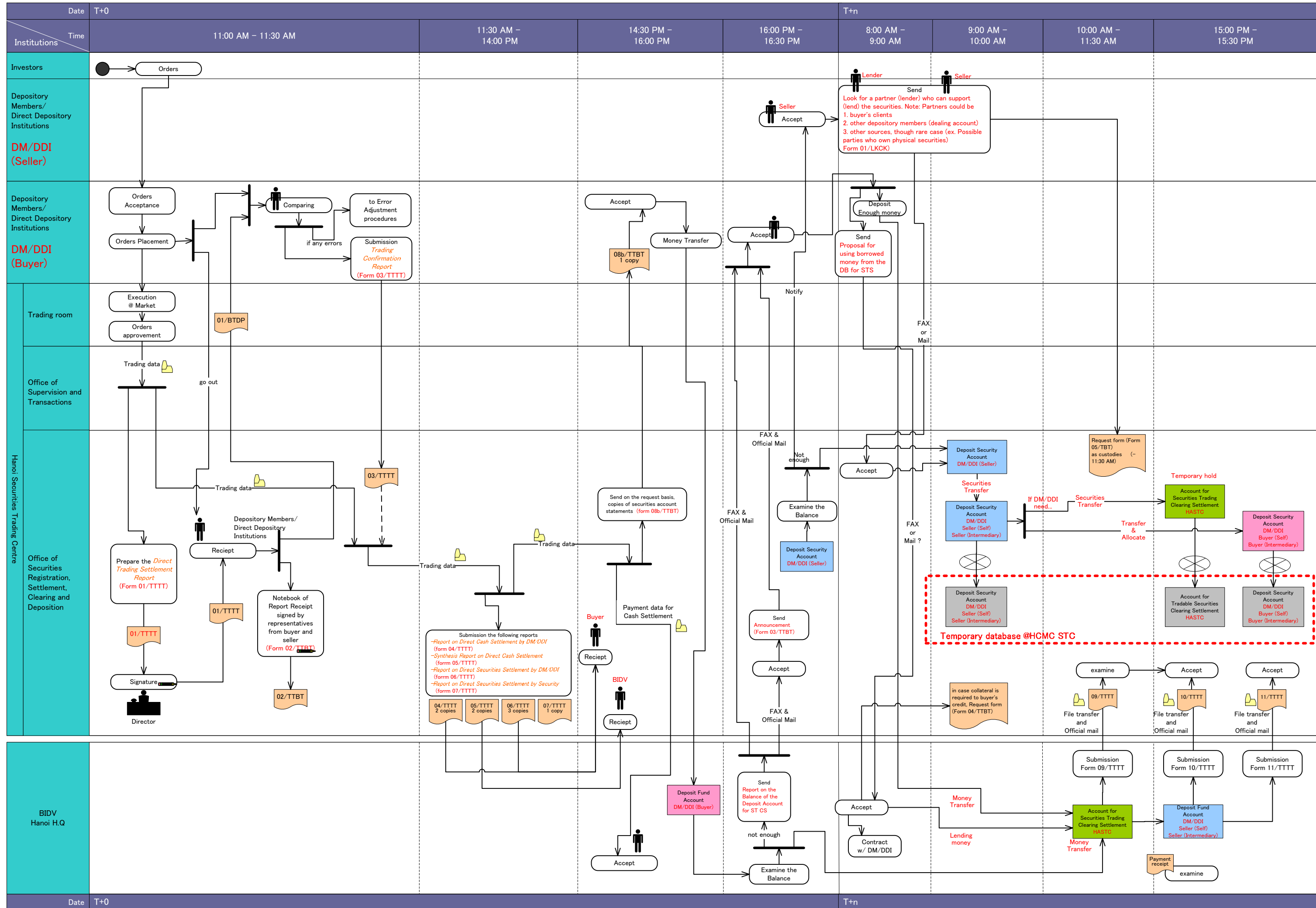

The Procedures for Settlement on the basis of Multilateral Clearing @ Ho Chi Minh City Securities Trading Centre (HOSTC) T+1

Ordinary Operation

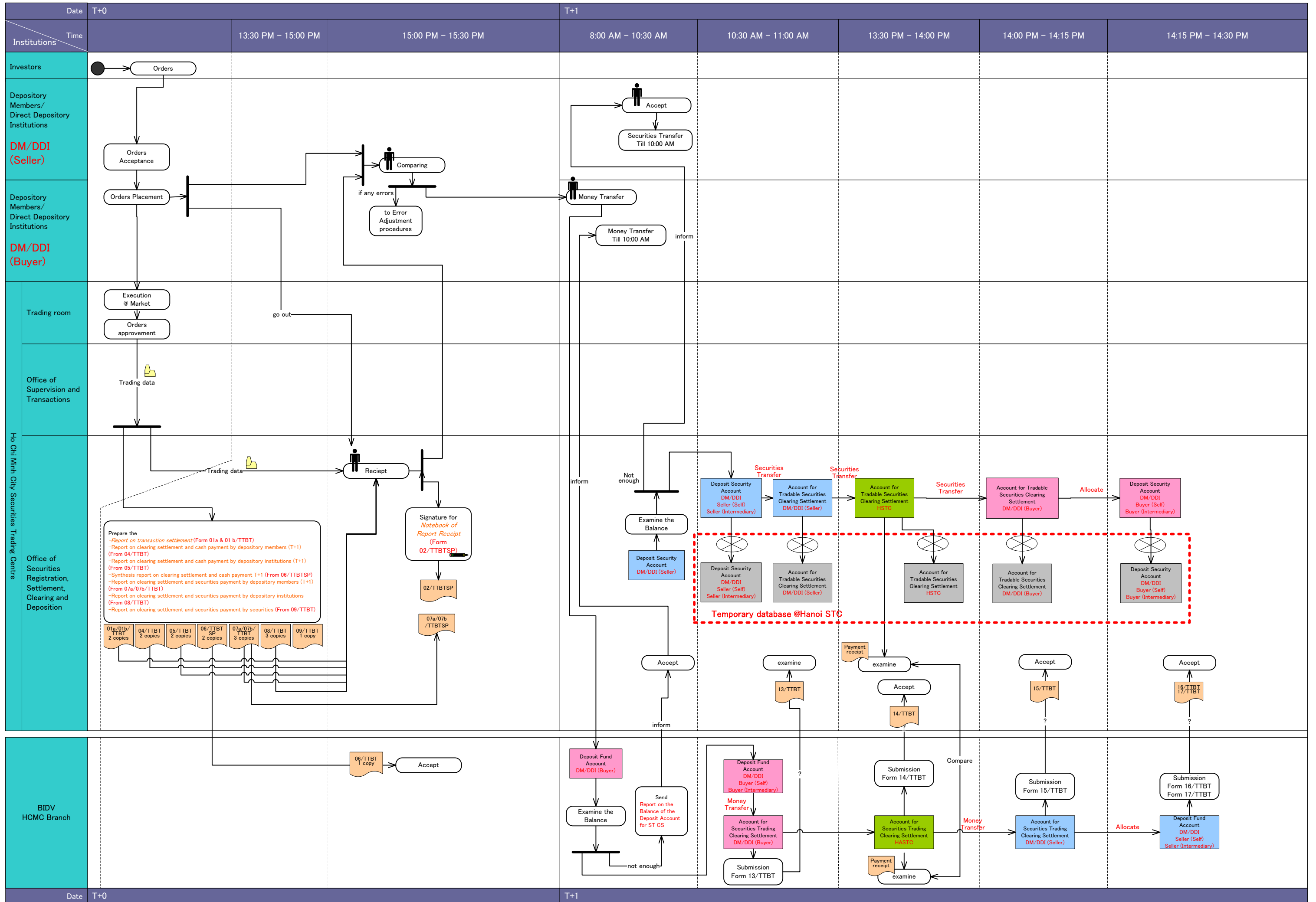

The Procedures for Settlement on the basis of Multilateral Clearing @ Ho Chi Minh City Securities Trading Centre (HOSTC)

Ordinary Operation

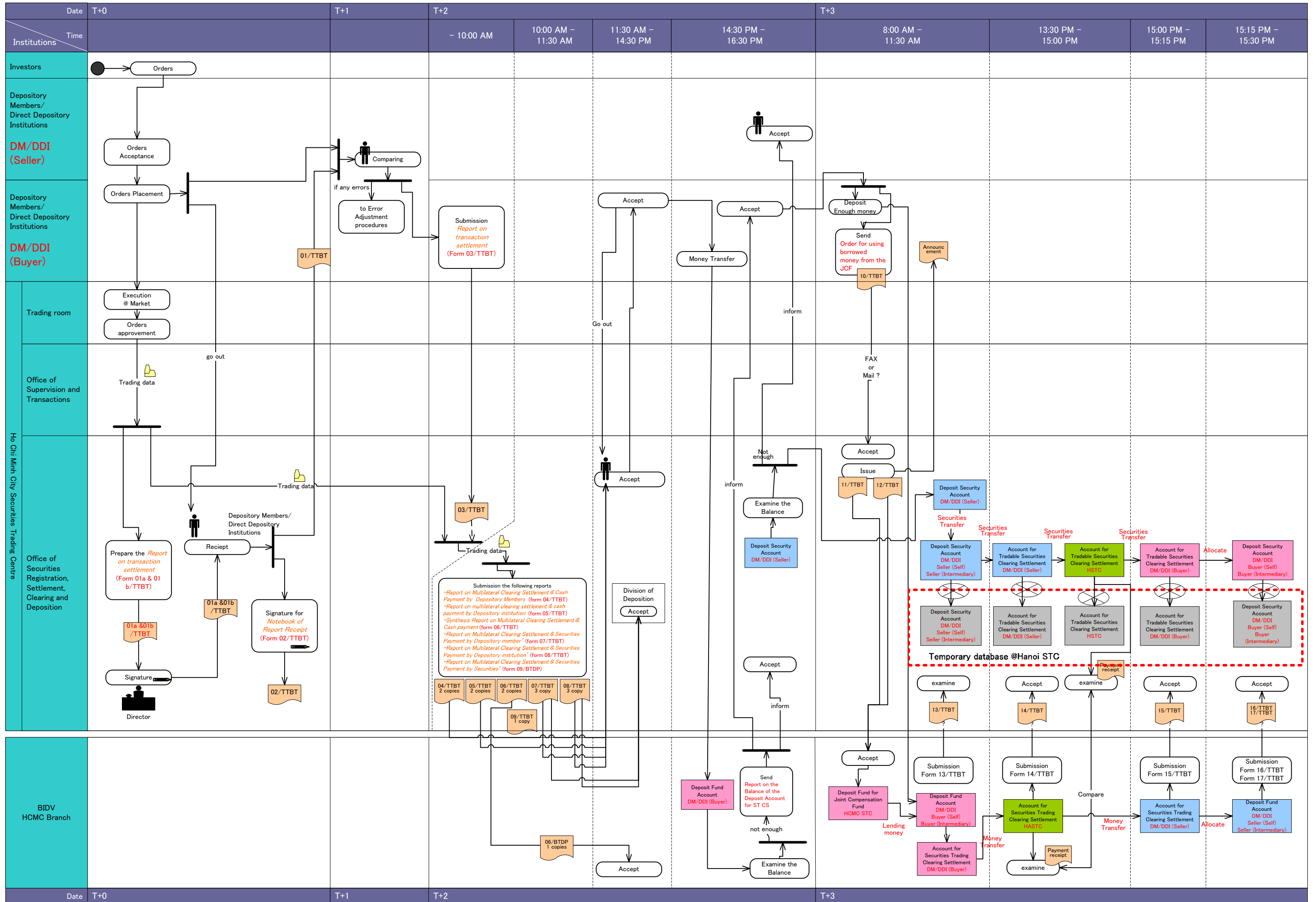

The Procedures for Settlement on the basis of Multilateral Clearing (T+3) HOSTC → HASTC Connection

Emergency case

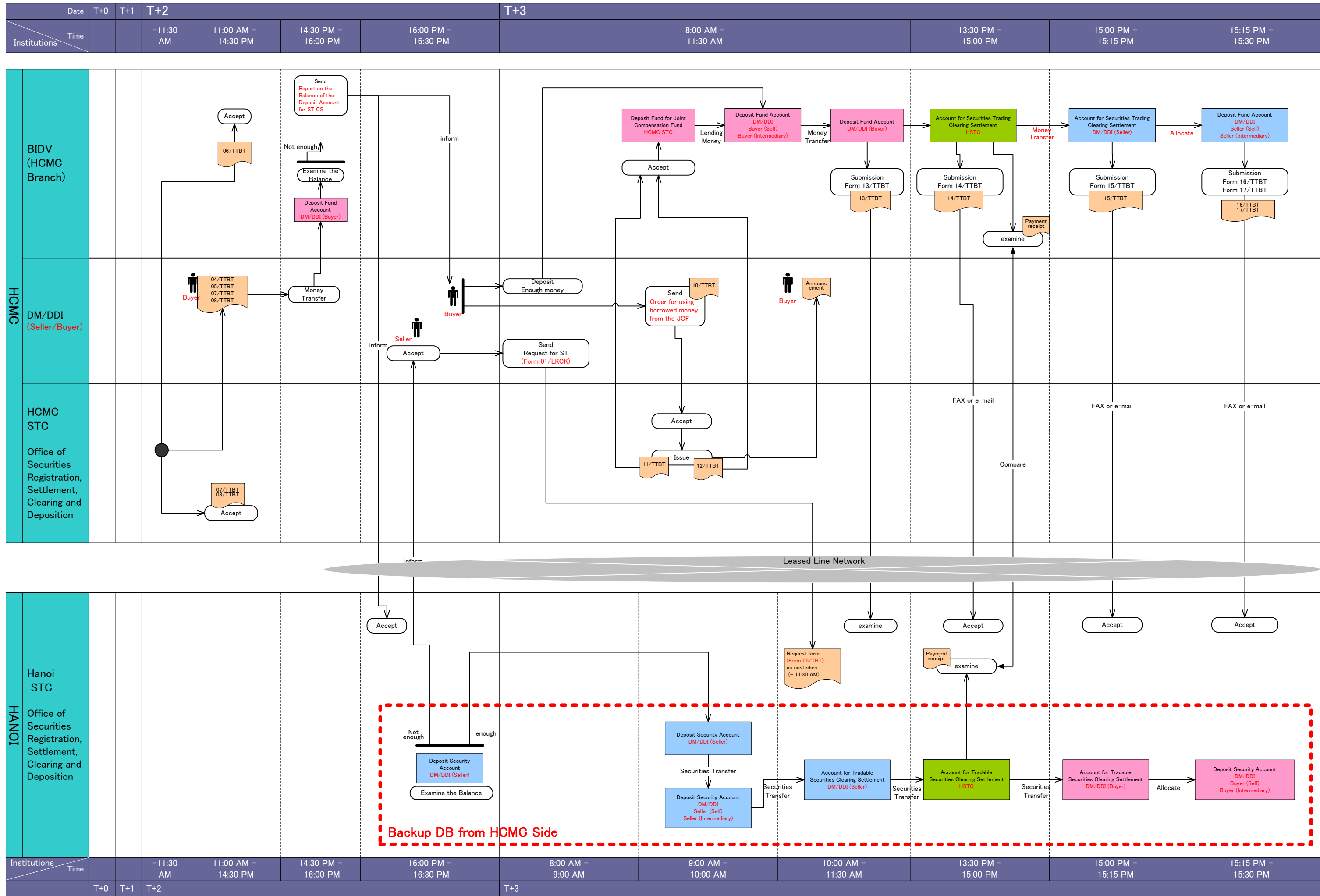

The Procedures for Settlement on the basis of Multilateral Clearing (T+3) HASTC -> HOSTC Connection

Emergency case

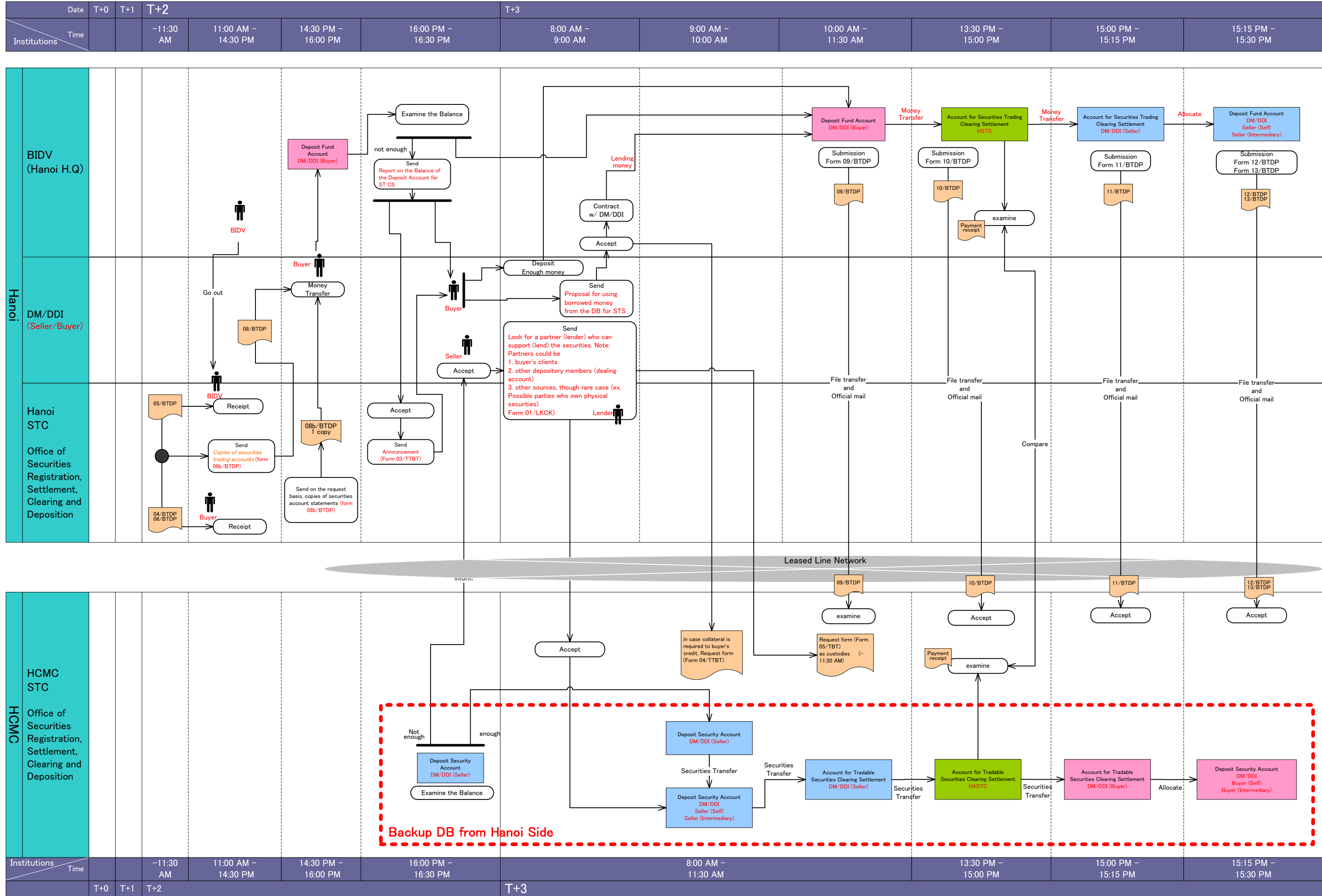

Appendix 4

4-1

Check Items			Check Points		
Large Items	Middle Items	Small Items			
Administration	Workflow	Internal workflow	<input type="checkbox"/>	Examine workflow at the 2 exchanges.	
			<input type="checkbox"/>	Examine staff at HASTC and HSTC after integration.	
		External workflow	<input type="checkbox"/>		
		Evaluation/Management	How to evaluate and manage	<input type="checkbox"/>	Examine management at the 2 exchanges, especially at Depository Section.
			Transition work		
			Rules	<input type="checkbox"/>	Make rules and operation manuals after integration.
			Training	<input type="checkbox"/>	Examine training program (plans, trainers, trainees, and curriculum)
				<input type="checkbox"/>	Order terminal equipment for training.
				<input type="checkbox"/>	Implement training.
			Media	<input type="checkbox"/>	Deliver important documents and boxes.
			Notes to related organizations and users	<input type="checkbox"/>	Discuss when and how to transit sensitive accounts.
				<input type="checkbox"/>	Discuss when and how to transit money accounts (if necessary).
				<input type="checkbox"/>	Examine how to notify changes and effective date.
			<input type="checkbox"/>	Examine procedures for the change.	
			<input type="checkbox"/>	Examine how to support users' work for the change.	

4-2

Check Items			Check Points		
Large Items	Middle Items	Small Items			
System specifications	System Functions	System functions	<input type="checkbox"/>	Comprehend structures and functions of systems at the 2 exchanges.	
			<input type="checkbox"/>	Examine relationship between monitoring and information systems at the 2 exchanges.	
			<input type="checkbox"/>	Examine when to stop adding new functions at current systems.	
			Necessity of relay systems	<input type="checkbox"/>	Examine how to integrate.
				<input type="checkbox"/>	Examine how to integrate completely.
			Functions of relay systems	<input type="checkbox"/>	Examine functions of relay systems.
				<input type="checkbox"/>	Examine interface between systems at the 2 exchanges.
			File specifications	<input type="checkbox"/>	Comprehend master and transaction files.
				<input type="checkbox"/>	Examine re-definitions and integration of the account number and codes for institutional investors, securities companies, transaction types, operations, internal system, and files.
				<input type="checkbox"/>	
		Performance/Capacity	Estimation of performance and capacity	<input type="checkbox"/>	Compute current and future traffic and capacity at the 2 exchanges.
				<input type="checkbox"/>	Analyze concentration of investors after the integration of the 2 exchanges.
				<input type="checkbox"/>	Compute traffic of relay systems.
				<input type="checkbox"/>	Implement tuning.
		Security measures	Security measures	<input type="checkbox"/>	Examine security measures of integrated system (facilities, technology, and operation).
				<input type="checkbox"/>	Examine security measures of relay system (facilities, technology, and operation).
				<input type="checkbox"/>	Examine plans at the 2 exchanges.
				<input type="checkbox"/>	Make security manuals.
			<input type="checkbox"/>	Implement training.	
	Operation/Maintenance	Operation/Maintenance	<input type="checkbox"/>	Examine and make operation rules including relay systems.	
			<input type="checkbox"/>	Implement operation training.	
			<input type="checkbox"/>	Monitor current systems.	

4-3

Check Items			Check Point
Large Items	Middle Items	Small Items	
	Transition system	How to transit	<input type="checkbox"/> Determine how to integrate servers.
			<input type="checkbox"/> Determine how to integrate terminal systems.
			<input type="checkbox"/> Confirm requirements and issues in transitioning securities settlement functions.
			<input type="checkbox"/> Examine how to transit databases.
			<input type="checkbox"/> Examine how to switch terminal systems.
			<input type="checkbox"/> Examine how to switch operation environment.
		Handling of existing data	<input type="checkbox"/> Examine necessity of using and/or saving existing data.
			<input type="checkbox"/> Examine how to save media, etc.
		Transition design	<input type="checkbox"/> Examine how to operate.
			<input type="checkbox"/> Examine how to manage schedule.
			<input type="checkbox"/> Examine how to validate.
			<input type="checkbox"/> Estimate transition time.
			<input type="checkbox"/> Make transition schedule.
			<input type="checkbox"/> Make transition manuals.
			<input type="checkbox"/> Implement transition rehearsal.
			<input type="checkbox"/> Review transition schedule and manuals.
			<input type="checkbox"/> Examine requests to the 2 exchanges and explain.
		Transition work	<input type="checkbox"/> Examine how to manage progress.
			<input type="checkbox"/> Examine how to communicate between the 2 exchanges.
			<input type="checkbox"/> Examine how to cope with unexpected events.

4-4

Check Items			Check Point	
Large Items	Middle Items	Small Items		
Software	Application/ Internal data	Application development	<input type="checkbox"/> Examine what language(s) to use and how to validate programs in integrated systems.	
	Software environment	Basic software structure	<input type="checkbox"/> Examine OS, control programs including DB, utilities, etc.	
		Make software environment	<input type="checkbox"/> Construct environment for development, test, etc.	
			<input type="checkbox"/> Examine how to manage environmental definition.	
Hardware	Equipment including computers	Function integration system (servers)	<input type="checkbox"/> Examine equipment structure after transition and select equipment.	
			<input type="checkbox"/> Examine how to switch hardware from current system.	
			<input type="checkbox"/> Examine unnecessary equipment.	
			Client terminal equipment	<input type="checkbox"/> Examine development equipment such as increase in CPU, DESK, and development terminal.
				<input type="checkbox"/> Examine necessary measures to client terminals such as remodeling.
				<input type="checkbox"/> Examine structure of client terminals.
				<input type="checkbox"/> Clarify changes and request to makers.
	Facilities	Computer center	<input type="checkbox"/> Examine schedule of selection, order, and delivery date of equipment.	
			<input type="checkbox"/> Examine how to switch client terminals.	
	Network	Internal network at HASTO	<input type="checkbox"/> Examine equipment layout.	
			<input type="checkbox"/> Examine construction schedule of A/C units, power supplies, equipment, etc.	
			<input type="checkbox"/> Examine spaces for staff and materials.	
			External network	<input type="checkbox"/> Examine internal network structure.
			<input type="checkbox"/> Arrange communication channels.	
			<input type="checkbox"/> Examine how to switch including appointment of vendors.	
			<input type="checkbox"/> Examine network to HOMO STC.	
			<input type="checkbox"/> Examine network to investors, securities companies, and settlement banks.	

Check Items			Check Date
Local Items	Mobile Items	Global Items	
Development support	Development standard Tools	Development standard	<input type="checkbox"/> Compare development standards of the 2 exchanges.
			<input type="checkbox"/> Make manuals on design and programming
			<input type="checkbox"/> Review and unify words.
			<input type="checkbox"/> Make rules on development and test including machine schedule and disk area.
		Development method	<input type="checkbox"/> Investigate development method and tools.
			<input type="checkbox"/> Examine tools for development assistance and performance test.
	Training	Training of development staff	<input type="checkbox"/> Examine staff assignment after integration.
			<input type="checkbox"/> Examine training programs of internal and outside staff.
	System assets Development materials	System asset management	<input type="checkbox"/> Examine how to manage outputs including documents, UCL, and application.
			<input type="checkbox"/> Examine safe storage of outputs.
		Development materials management	<input type="checkbox"/> Confirm a peak of each development period.
			<input type="checkbox"/> Examine how to manage inventories.
Project management	Project Index	Quality control	<input type="checkbox"/> Examine quality control standard.
			<input type="checkbox"/> Examine how to control quality.
		Progress management	<input type="checkbox"/> Make master schedule.
			<input type="checkbox"/> Make master schedule tables.
			<input type="checkbox"/> Schedule management (who to be check, how often, etc.)
	Organization/ Staff	Plan for organization and staff	<input type="checkbox"/> Examine organization.
			<input type="checkbox"/> Examine roles of organizations.
			<input type="checkbox"/> Examine staff.
	Cost	Management of expenses	<input type="checkbox"/> Comprehend reasons of expenses.
			<input type="checkbox"/> Examine how to manage expenses in development, transition, and operation.